

► ICE / PVE Vibrator Set

■ PVE 24 VM *Vibratory Hammer*

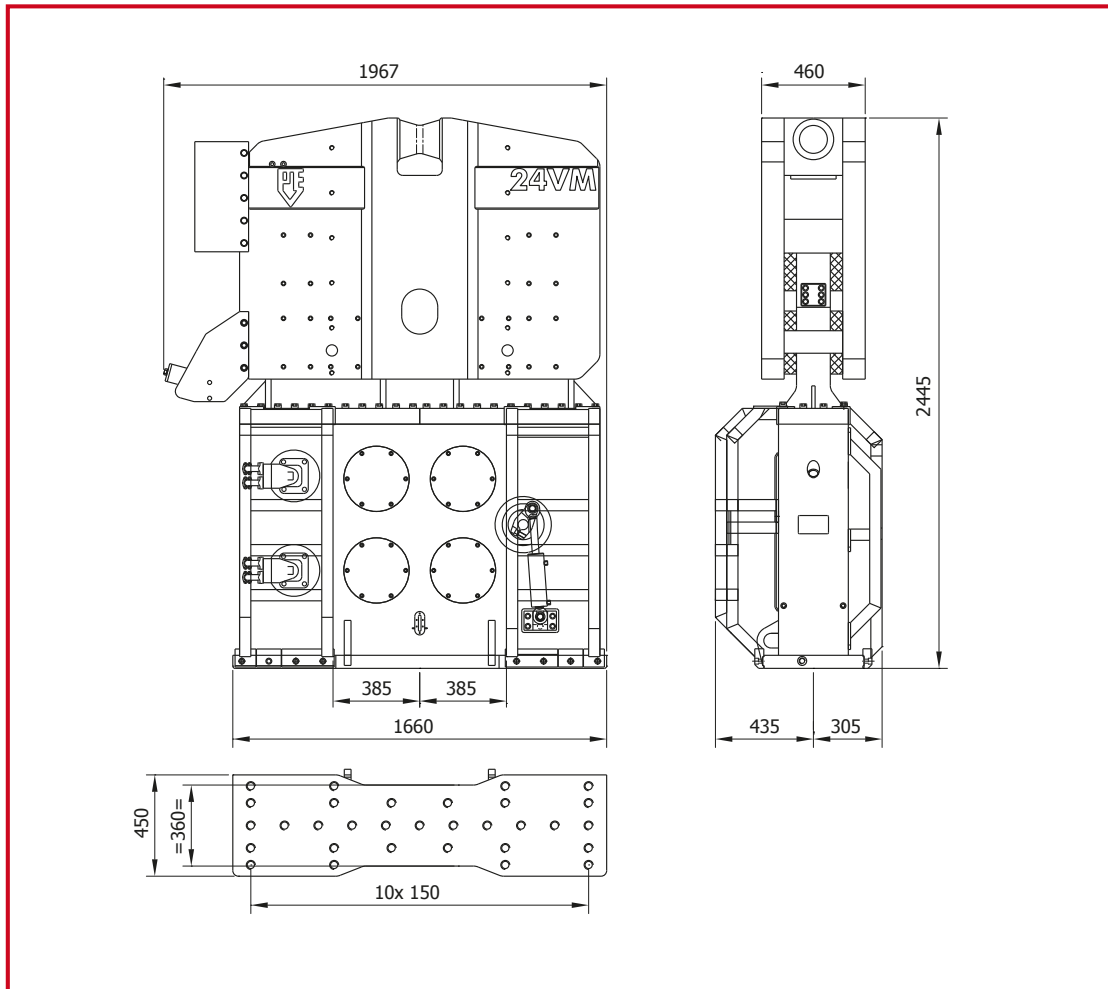

Specifications		24VM	
Eccentric moment	0-24	kgm	
Max. centrifugal force	0-1400	kN	
Max. frequency	2300	rpm	
Max. amplitude excluding DWK 200T	14	mm	
Max. amplitude including DWK 200T	8.7	mm	
Max. static line-pull	400	kN	
Max. operating pressure	350	bar	
Max. oil flow	493	l/min	
Forced lubrication	yes		
Dynamic weight excluding DWK 200T	3500	kg	
Dynamic weight including DWK 200T	5500	kg	
Total weight excluding DWK 200T & hoses	6020	kg	
		Clamps:	
		Sheet pile clamp	DWK 200T
		Transport weight per piece	2000 kg
		Double clamps	PPK 80T
		Transport weight per piece	500 kg
		Powerpack:	
		Model	500
		Hose set:	
		Length	30 m
		Transport weight (±)	kg

► ICE / PVE Vibrator Set

■ PVE 600 PP *Hydraulic Power Pack*

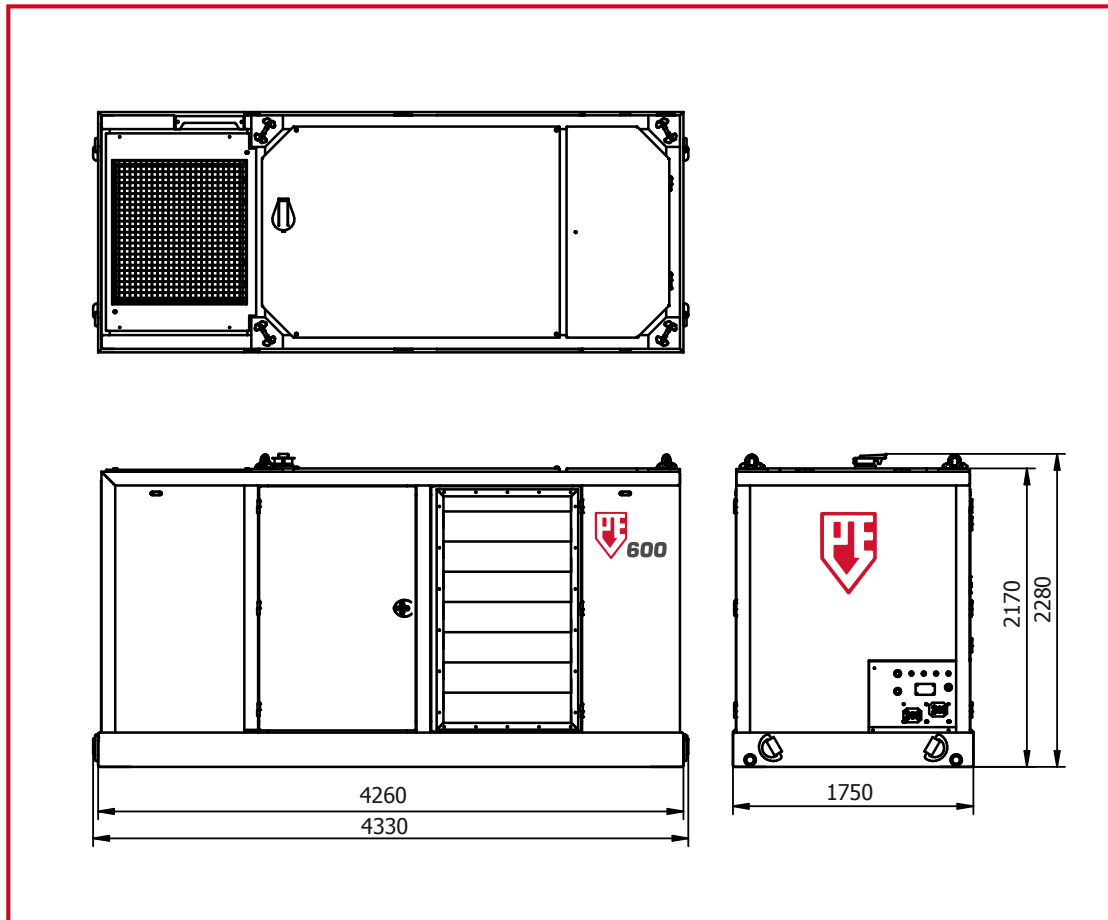

Specifications	600	
Diesel engine	Volvo TAD 1385 VE	
Max. theoretical power	405/551	kW/HP
Max. frequency	1900	rpm
Max. operating pressure	350	bar
Hydraulic pump	Parker	
Max. oil flow	617	L/min
Diesel oil	790	L
DEF (AdBlue) capacity	45	L
Hydraulic oil	1345	L
Weight without fuel	6900	kg
Weight filled up	7600	kg

► ICE / PVE Vibrator Set

■ PVE 200 T *Universal Clamp*

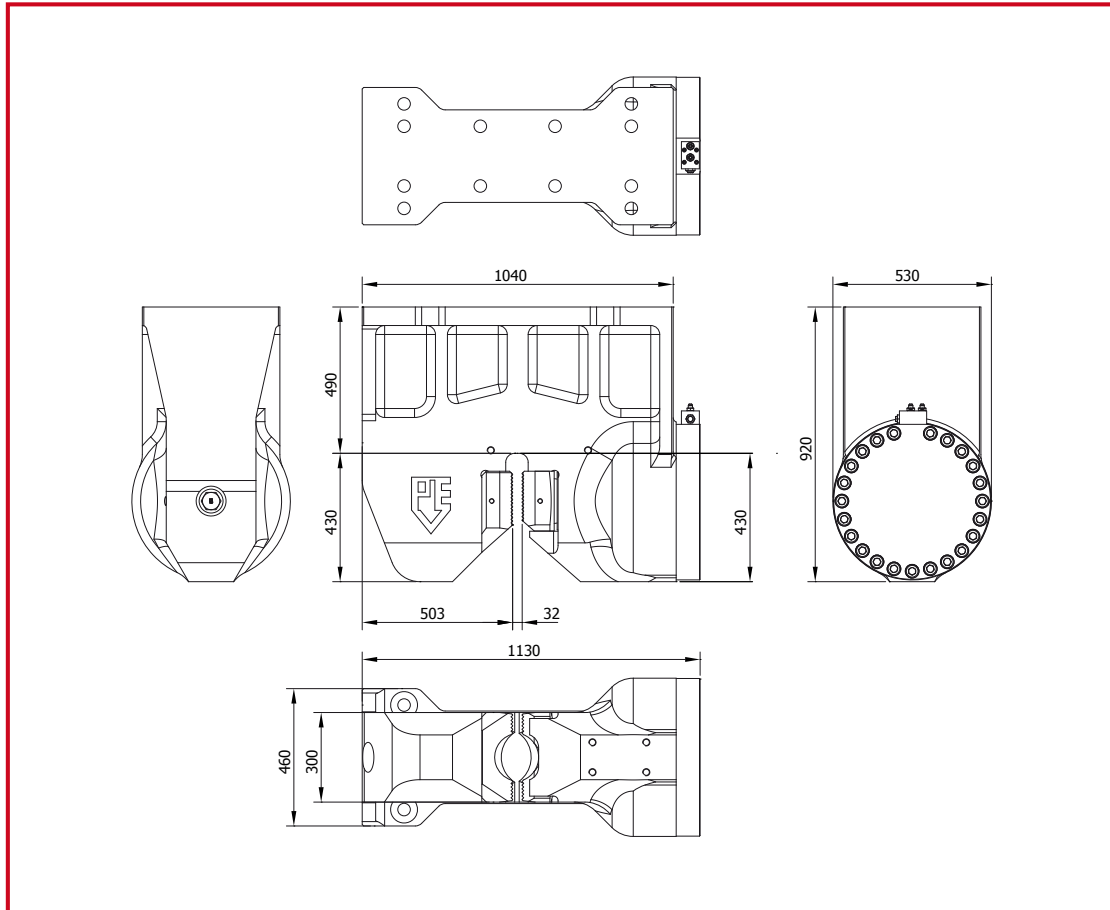

Specifications	Technische Daten	Spécifications	Specificaties	Especificaciones	
Sheet pile clamp	Spundwandzange	Pince palplanches	Damwandklem	Hoja abrazadera pila	
Clamping force	2000 kN	Klemmkraft	Force de serrage	Klemkracht	Fuerza de sujeción
Max. operating press.	300 bar	Max. Betriebsdruck	Pression de travail max.	Max. werkdruk	Presión máx. de trabajo
Max. clamp open press.	180 bar	Max. Druck Zange Offen	Pression pince ouvert max.	Max. klem open druk	Presión abrazadera aperto máx.
Weight	2000 kg	Gewicht	Poids	Gewicht	Peso