

► ABI Mobilram

■ TM 13/16 SL

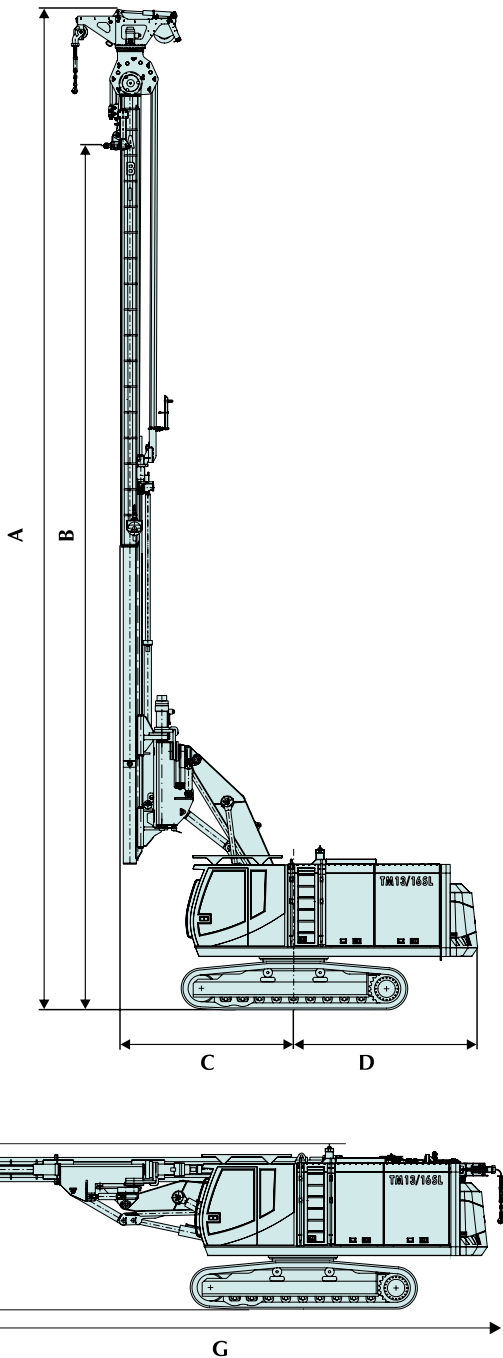

Technical data	Unit	TM 13/16 SL
Leader inclination front/rear	degree max.	4/5
Leader inclination laterally	degree max.	4
Leader slewing range	degree max.	+/- 100
Prestressing force leader cylinder	kN max.	90
Extraction force leader cylinder	kN max.	175
Load capacity	kg max.	9000
Torque absorption	daNm	4500
Auxiliary winch lifting capacity	kN max.	50
Auxiliary winch rope speed	m/min	35
Weight - depending on carrier unit**	t approx.	45 - 50
VIBRATOR		MRZV 20 VV
Dimension		
A Height min./max.	mm	10900 - 20650
B Max. height up to rapid changing device	mm	17830
C Center to guide	mm	3550 - 5180
D Center to back underground lowering depth	mm	3800 - 4100 2985
E Leader mast guide width	mm	500
F Leader mast width	mm	50
G Length / transport	mm	12000
H Height / transport	mm	3400
Width / transport	mm	3000

BASE CARRIER	Unit	SR 35 T-E
ENGINE		
ENGINE		CAT C18
Engine power EU Stage Tier 4 final	kW	470
Hydraulic flow rate	cm ³	2 x 210 1 x 95, 1 x 60
Nominal oil pressure	MPa	33
Fuel tank capacity	l	810
Standard undercarriage		
Pulling force	kN	350
Track gauge	mm	2400
Outriggers - / Track shoes width	mm	600*
Optional - Hydraulic extendable undercarriage		
Pulling force	kN	340
Track gauge	mm	2200 - 3300
Track shoes width	mm	700*

*Optional track shoes width 700, 800, 900 mm