

► ABI Add-on vibrators

For smaller projects ABI offers attachments for hydraulic excavators. The add-on **vibrator HVR** is mounted at the dipper stick of a hydraulic excavator boom and driven by its hydraulic system.

Apart from characteristics like very short starting and stopping times, high revolutions, low noise level as well as low weight and high centrifugal forces, the HVR is characterised by a short design height. This advantage appears particularly in buildings, under bridges or power lines. Little usable length is lost due to its small design height. The add-on vibrator is used for piling and extracting sheet piles, trench sheets, steel beams and girders, pipes and casings as well as full displacement sections.

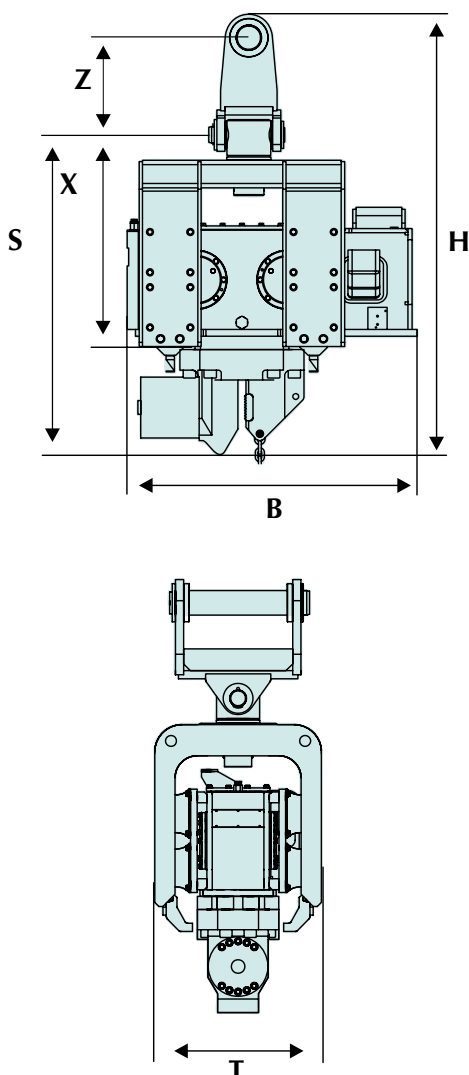

■ HVR 30

Technical data	Unit	HVR 30
Static moment	kgm	3
Dynamic mass	kg	565
Nominal revolutions	min ⁻¹	3000
Centrifugal force at nominal frequency	kN	300
Static extraction force max.	kN	40
Nominal oil pressure	MPa	32
Hydraulic flow rate	l/min	90
Hydraulic power at p max.	kW	50
Total weight / transport weight	kg	890 / 975
Weight of pile elements	kg	500

Dimension / mm	HVR 30
H Height	1560
B Width	850
T Depth	610
S Locking to bottom	1120
X Locking to vibrator body	740
Z Excavator connection standard	352
Transport dimensions H / B / T	1670 / 1000 / 660