

TWF TIEFBAUTECHNIK

Sales | Rental | Leasing



SHORING BOX PLATFORM
WALKWAY AND FALL ARREST SYSTEM

www.twf-tiefbautechnik.de

www.twf.at

OPERATING MANUAL

► TWF - Shoring Box Platform

Table of contents

1. INTRODUCTION TO SYSTEM APPLICATIONS		5. FALL CLEARANCES	10
1.1 Specifications	3	6. TRAINING	10
1.2 Material & Construction	3	7. PLATFORM SYSTEM USAGE	10 - 11
1.3 Safety Instructions	3-4	8. INSPECTION	
1.4 Site Hazards	4	8.1 Daily Inspection Procedure	12
2. APPLICATION		8.2 Annual Inspection	12
2.1 Limitations	4	9. MAINTENANCE	
3. GENERAL SYSTEM REQUIREMENTS		9.1 Cleaning & Lubrication	12
3.1 Mounting Requirements	5	9.2 Packaging	12
3.2 Connectors	5	9.3 Packing of Shipping Box (Stillage)	12-13
3.3 Full Body Harness	5	10. INSPECTION LOG	14
3.4 Fall Protection	5	11. DEFINITIONS	14
4. SYSTEM INSTALLATION		12. MARKINGS AND LABELS	
4.1 Shoring mount ladder access platform	5-7	12.1 Label Location	15
Unpacking from Stillage		12.2 Label Definitions	16
4.2 Shoring mount ladder access platform	7-9	13. Copy of EC declaration of conformity	17
site set up			

The product has been tested to:
AS/NZS5532:2013
AS/NZS1657:2018
EN795:2012
and complies with the Basic
Health & Safety requirements
of New PPE Regulation (EU) 2016/425
Module D

Code: 30125B **BIRENCHSAFE** Fall Arrest Post Kit
Code: BTS6928-LP EU **BIRENCHSAFE** Shoring mount ladder access
Code: BTS6928-TW EU **BIRENCHSAFE** platform Access walkway



CE2797



► Operating & Safety Instructions

1. INTRODUCTION TO SYSTEM APPLICATIONS

This system features high quality lightweight aluminium extrusions and easy to adjust clamping screws. The TWF Shoring Box Platform System with Fall Arrest Post, has been specifically designed and engineered to provide access and egress to or from an excavation that can be used on standard aluminium or steel shoring panels with minimum thickness of 50mm and up to 200mm.

The product has been tested to **AS/NZS5532:2013 & EN795** and complies with the **Basic Health & Safety requirements of New PPE Regulation (EU) 2016/425**

1.1. Specification

Capacity: 1 worker at 136 kg including all clothing, tools and equipment.

1.2 Material & Construction

Structure: Extruded Aluminium

Hardware: Graded / Galvanized

Finish (aluminium): Mill Finish

The use of this equipment in some work places may require documented training from a Registered Training Organization, therefore, BTS recommends

1.3 Safety Instructions -

MUST BE READ PRIOR TO USE

- Prior to use, ensure all operating procedures have been read and understood (if you have difficulty in reading the instructions, have someone read them to you).
- System only to be used by someone who is competent in its use.
- Use appropriate personal protective equipment (PPE) when installing and using /mounting the platform system.

Minimum Suggested PPE (Personal Protective Equipment)



Protective Footwear



Protective Gloves



Safety Vest



Hard Hat



Eye Protection



Harness (Fall Arrest)

- **Work area** - All non-operational bystanders are to be kept clear of work area.

- **Pinch points** - Always wear gloves and beware of pinch points during installation and operation.



- **Lifting requirements** - Ask for assistance when lifting/ moving heavy components. Before lifting, take an extra step to position your body close to the load. Remember to keep a straight back, use your leg muscles to take the weight and avoid twisting when lifting or carrying a load.

- **Slips, Trips and Falls** - Be aware of soft or uneven ground near the excavation site and keep work area clear of excess tools, equipment etc.

- **NOTE: Do not use the walkway or ladder access platform if surfaces have dirt/debris build up and exercise caution when they are wet or slippery.**

- This system is only to be installed by competent persons who have an understanding of the dangers associated with excavations and ground collapse hazards (Guidance can be sought from Excavation and onstruction Codes of Practice).

- This system is fitted with an attachment point rated for Limited Free Fall and is only to be used by competent persons who have been trained in the safe use of the system and associated equipment.

- Ensure all workplace OH&S requirements are identified and understood. A risk assessment complete with a site specific safe work method procedure must be completed and approved by management prior to work commencing.

- This system requires periodic inspection and maintenance by a competent person (as described in EN361:2002). The system **"MUST NOT"** be used if any part of it is overdue for service, inspection or is damaged.

- A rescue plan must be devised and be ready to be implemented prior to usage of a fall arrest system.

- Only approved full body harnesses, certified to EN361:2002, are to be used with this system.



► TWF - Shoring Box Platform

- The system is designed to be used for Limited Free Fall Arrest and requires that BTS Self Retracting Lifelines (SRL's) be used. SRL's selected for use with this system must have a Maximum Arrest Force (MAF) rating of 4kN or less.
- Visually inspect the system for damage prior to use. The system must not be used if there is any deterioration or deformation of any components or the structure to which the system is attached.
- Similarly if the system has arrested a fall, tag "Out of Service" and do not use until it has been fully inspected and recertified by a competent person.
- Ensure all fixings, fittings and components are securely attached. Any tightening, adjustment or replacement of components must be carried out by a competent person, using only BTS genuine parts.
- All applicable EN Standards, OH&S Acts & Regulations, Codes of Practice and Guidelines must be read and followed when using this safety system.
- This user manual does not in any way replace the need for completion of a recognised height safety training course by a Registered Training Organisation (RTO).
- Do not use the system if medically unfit. A person with muscular, skeletal and physical disorders should consult a physician before using Personal Fall Protection Equipment. Increasing age or lowered physical activity may reduce a person's ability to use this equipment.

1.4 Site Hazards

Sites have associated with them many hazards which must be considered before using any equipment or performing tasks. These include but are not limited to:

- Overhead power lines, transformers (both mounted aerially and at ground level), underground power, solar power systems (please note that solar panels generate electricity whilst exposed to sun light and wires between the panels and the first isolator cannot be turned off).
- Overhead power lines, transformers (both mounted aerially and at
- Gas lines (both underground and on the surface)
- Ground collapse hazards (such as sand and uncompacted soils)
- Chemicals
- Plant and machinery
- Traffic (both vehicular and pedestrian)

Failure to follow all safety, installation, usage and maintenance instructions may result in serious injury or death.

2. APPLICATION

TWF Shoring Box Platform System is designed to provide a means of access and egress to excavations protected by a shoring system. It is equipped with a securing system for a ladder and a connection point for an SRL.

There are restrictions and limitations that must be carefully considered in the selection, installation and operation of this equipment.

Serious injury or death may result from failure to consider factors outlined in the following paragraphs.

2.1 Limitations

BTS recommends that any and all persons using this system do not work alone in case of an emergency and/or help is required.

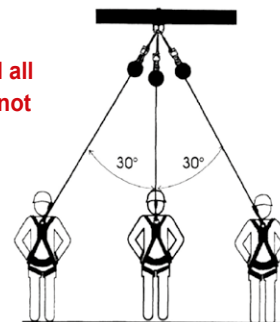

MUST BE READ PRIOR TO USE

- Only to be used by persons with documented proof of training in the use of height safety and fall protection systems.
- The TWF Shoring Box Platform System is suitable for a single user to be attached at any one time. Check system specifications or contact BTS for configuration limitations.
- Operators of this system must be connected via an SRL, which will limit any fall to less than 600mm. The system must be set up so that the user will not be offset by more than 30 degrees from vertical, as per EN361.
- Do not modify any of the system components.
- This system is not to be used for lifting.



► Operating & Safety Instructions

3. GENERAL SYSTEM REQUIREMENTS

3.1 Mounting Requirements

The system is designed to be mounted on the top edge of a shoring system (aluminium or steel) which is capable of safely supporting the weight of the system plus all static and dynamic loads that may be applied to the system during use.

There must be enough of the top edge of the shoring structure exposed to allow the platform to be secured using the clamp screws. The Shoring Platform also requires that there is enough width between the shoring box struts to allow the access ladder to sit at a suitable angle (as per industry guidelines, an angle of 4:1 is preferred unless the system has been set up to use the ladder vertically)

The system must be mounted keeping in mind that the Maximum deflection of anchor device when in service will be approximately 15mm (elastic deflection). During service, the system is expected to transmit a load of approximately 300kg onto the shoring structure.

Note: All installations MUST BE approved by a competent person and used under the supervision of a competent person.

3.2 Connectors

All connectors used to connect components in the system must be compatible with each other to ensure sufficient strength and eliminate the risk of accidental disengagement or rollout during use. Connectors supplied with products designed, manufactured and/or approved by BTS meet all applicable requirements for connectors (refer to EN361:2002). Any connectors not supplied by BTS MUST BE selected and approved by a competent person.

3.3 Full Body Harness

Use only a full body harness designed, tested and approved for fall arrest (refer to EN361:2002) when connecting a person to this system.

Warning: Body belts or straps MUST NOT be used, as they do not provide adequate restraint / support to the body, and may cause serious injury or death in the event of a fall.

3.4 Fall Protection

Activities involving working at heights require the use of personal protection equipment (PPE) to protect the worker in the event of a fall. Suitable fall protection must be provided as required by applicable local regulations when using this equipment. Fall protection equipment MUST be selected and

installed under the supervision of a Competent Person.

4. SYSTEM INSTALLATION

The system can only be installed by a competent person that has fully read and understood this manual. As the system is to be installed at an elevated level above an excavation protected by a shoring system, a number of licences and qualifications may be required under site specific requirements, Local, State and Federal law.

The system is only as strong as the structure/shoring box that it is mounted on, therefore it is imperative that the shoring be installed as per the manufacturer's instructions.

Please note that Installation records need to be kept and maintained by the user for future installations and inspections. This record must include information such as the details of the installer, the address and location of installation, product identification and procedures and/or product or tools used for the installation. This document must be signed off by the installer.

For further details, please refer to Annex A.2 of EN795:2012

4.1 Unpacking of Shipping Box (Stillage)

The system is supplied packed into a steel shipping box (Stillage) to facilitate easy storage, transport and stacking of multiple units. The system need to be unpacked before use and repacked before transport to another site.

Please follow the unpacking directions below and on the following pages.

Note: Item described in each step is highlighted in the diagram in BLUE

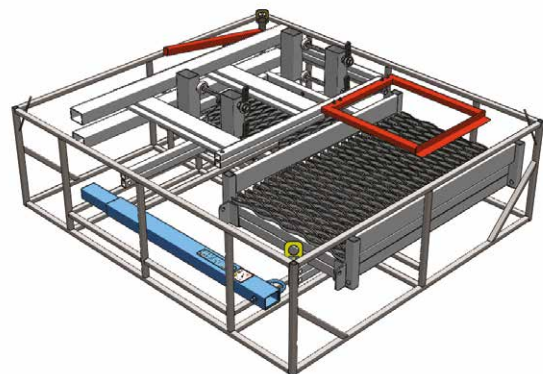

- 1 Release the packing straps and remove the Anchor Post

09-2023



► TWF - Shoring Box Platform

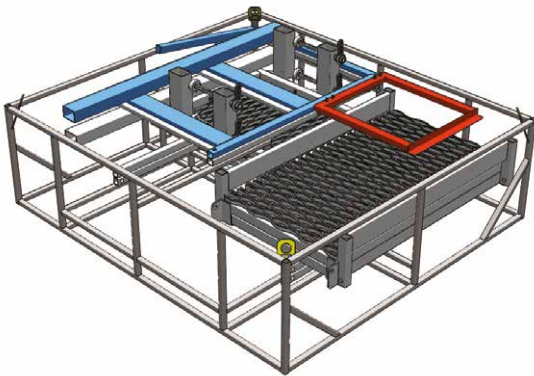

2 Release the packing straps and remove the top Platform Guardrail

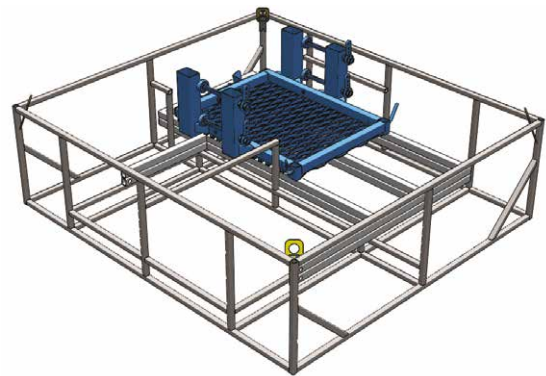

5 Remove the Platform, turn over (feet facing down).



3 Remove the Platform Guardrail with the spring loaded gate on top of the walkway.

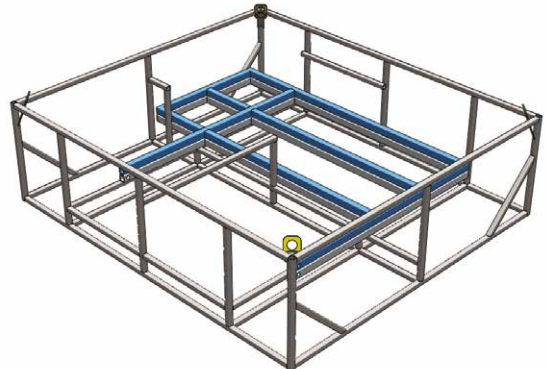

6 Remove the top Walkway Guardrail

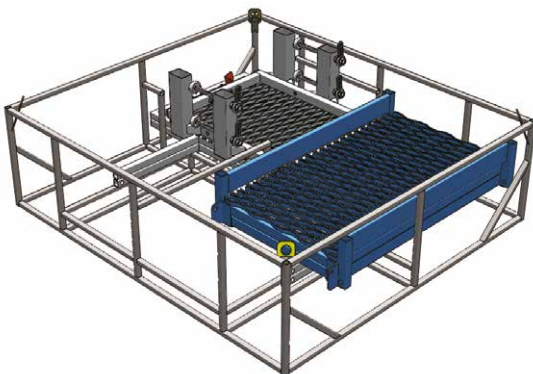

4 Release the packing straps and remove the walkway.

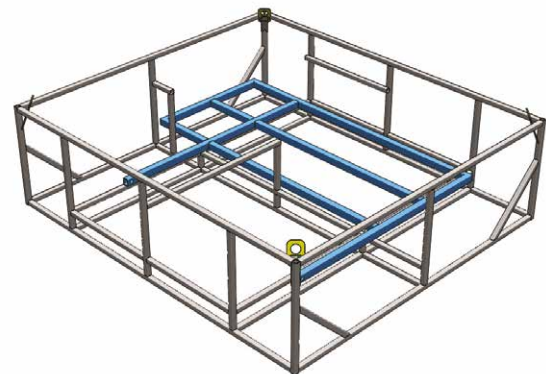

7 Remove the bottom Walkway Guardrail



► Operating & Safety Instructions

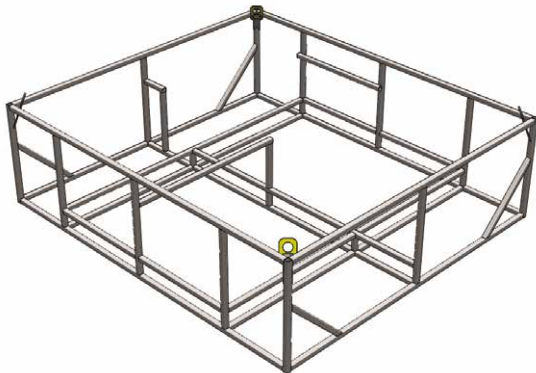

- 8** Store stillage & packing straps in a safe place to ensure no damaged.
Note: Stillage is to be repacked if the system is to be transported or stored.
 (See repacking of Stillage Page 13)

4.2 Shoring mount ladder access platform - Site set up

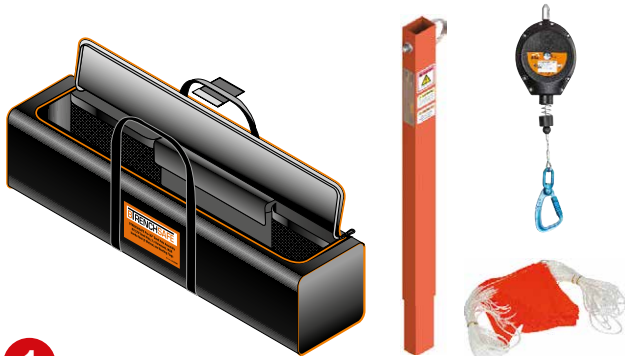

- 1** Identify the TWF Davit anchor pole Kit (Code 30125BKIT)
- 1 x Carry Bag
 - 1 x 1.0 metre Davit anchor post c/w large 'D' anchor point
 - 1 x IKAR inertia reel (9 metre)
 - 1 x Bunting tag line (30 metre)

Identify the shoring mount ladder access platform components:

- 1 x Shoring box platform
- 1 x Walkway with removable guardrails
- 1 x Locking bar for walkway

The TWF Shoring mount ladder access platform also includes:

- 4 x Clamp screws
- 1 x Ladder bracket & screws
- 2 x Extension arms
- 1 x Self-closing gate
- 1 x Access bar

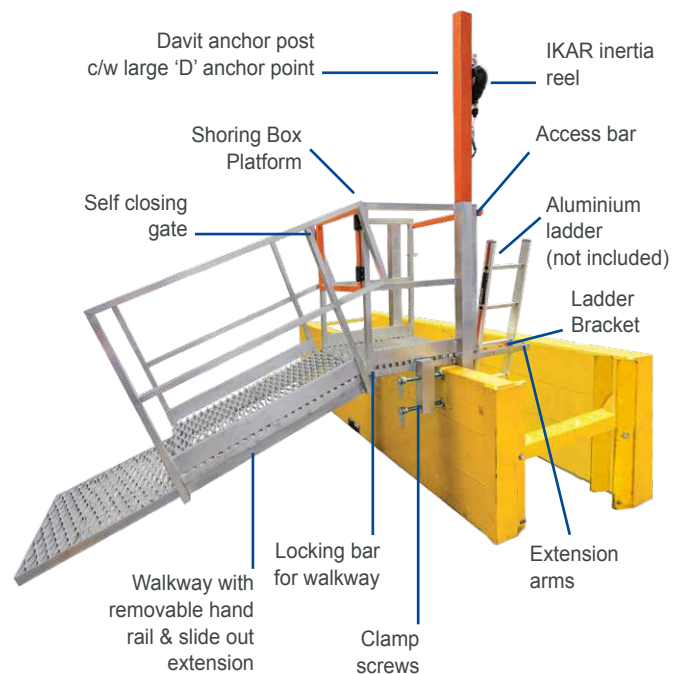

NOTE: The ladder to be used with the system is recommended to fall within the following range of dimensions: Internal Distance between stiles: Minimum 305 mm and maximum 330 mm

- 2** Inspect the components for wear and damage that may have been sustained either in use or during transport. If any of the components are damaged or deemed unfit for purpose, tag them "Out of Service" and contact your supervisor prior to commencing installation. Re-use the system only if confirmed by a competent person, in writing, that it is safe to do so.



► TWF - Shoring Box Platform

3 Before mounting the TWF Shoring Mount Ladder Access Platform ensure that the shoring has been installed as per the manufacturer's instructions and that there is sufficient panel available to mount the platform (approximately 200mm in height and 1000mm wide).

At this point also check that the soil around the shoring box is stable (look for fissures, cracks, signs of water, services or previous excavations) and make an assessment of the potential for ground collapse.

Note: Never walk between an excavated area and a shoring wall without first checking that it is safe to do so.

If there is any doubt as to whether it is safe to proceed, seek the guidance of a suitably qualified person or from local Excavation Work Codes of Practice or equivalent, if available.

4 Fit the Davit Anchor Post to the Shoring Platform (the anchor post needs to be fitted on the same side of the platform as the access ladder. When the ladder is mounted to the front of the platform, the anchor post can be mounted on either side of the platform).

Pull out the extension arm from under the Shoring Platform. Listen for the noticeable click indicating that the extension arm is fully extended and that the **BTS click** has locked into place. Ensure that you select the extension arm that is on the same side as the davit anchor post.



On some sites it may be necessary that installers are wearing a safety harnesses and attached to a temporary fall protection system before approaching the shoring panel. If required, fit the harness and install the temporary fall protection system as per manufacturer's instructions.

Select a suitable location on the shoring panel that will allow the access ladder to run at an appropriate angle from the ladder bracket to the base of the excavation (as per industry guidelines, an angle of 4:1 is preferred).

Mount the TWF platform to shoring box (this is a 2 person lift or use a crane, Hiab or suitably rated excavator approved for lifting). Once the platform is sitting on top of the shoring, tighten the 4 clamp screws to 65Nm or as deemed tight enough by a competent person using the integral handles provided (never use a cheater bar, rattle gun or socket and bar).



BTS click

5 Now carry the walkway to the platform with the aid of a second person and attach it to the pivot points located on the TWF Shoring Mount Ladder Access Platform. The walkway is connected to the platform using the locking bar



The locking bar is inserted through the pivot points on the platform and walkway from the opposite side to the securing clip (the securing clip is located using a short lanyard which is permanently connected to the platform). When fitting the walkway, keep fingers clear of crush and pinch points.





► Operating & Safety Instructions

- 6** If the guardrails were not already fitted to the walkway, they can now be installed by sliding the railing uprights into the receiver tubes located on either side of the walkway.



- 7** The walkway is fitted with a pull out extension piece which allows the walkway to come into contact with the natural ground level (or top of the excavated area) minimising the walkway angle. Adjust the length of the extension section until the desired angle is achieved (steep angles must be avoided to minimize the risk of slip injuries).



Now connect the SRL to the fall arrest anchor point on the Davit Anchor post. Ensure that the platform access bar is closed before attaching the SRL.



The SRL is connected using a screw gate karabiner. Once closed, screw the karabiner gate keeper to the end of its travel to stop accidental opening.



Now a suitable ladder can be attached to the platform. The installer must be wearing a full body harness (approved to EN361:2002) and be connected to the anchor point (located on the anchor post extension) via the SRL (approved to EN360:2002).

For deep excavations where long extension ladders are used, a mobile crane, Hiab or an excavator approved for lifting may be required to lower the ladder into position.



Once the ladder has been lowered into the excavation and the angle is correct, install the ladder securing bracket and the 2 clamp screws. Ensure that the ladder bracket is in the correct orientation.

The ladder must protrude at least 1 metre above the ladder bracket so that it can be safely accessed when climbing down and safely alighted from, when climbing out of the excavation (except when the ladder is connected to the leading edge of the platform).



Seek your local "Codes of practice: managing risk of falls" or relevant guidance for correct set-up of ladders.



► TWF - Shoring Box Platform

5. FALL CLEARANCES

Before commencing work, ensure there are adequate fall clearances and that all obstructions have been removed where possible. To work out whether there is enough distance available, you should take into account:

- The worker's height.
- The height and position of the anchorage point.
- The length of the SRL's Body.
- Free Fall Distance.
- Deceleration Distance.
- Harness Stretch.

Guidance can be found in EN363



6. TRAINING

All persons using this equipment must receive appropriate training from their employer on all equipment involved prior to operating. Users must also read and fully understand this manual and any other instruction manual(s) relating to the system being used, or have the instructions fully explained to them before using this equipment.

Additionally, users must be properly trained in the use of any accessories that are to be used with the platform system, as well as fall protection, confined space safety and any other procedures that are applicable to the work being performed; in compliance with local regulations.

Note: Documented training records should be kept for all users of this equipment.

7. PLATFORM SYSTEM / USAGE

1. Before using the system, fit a full body harness (compliant to EN361:2002) and ensure that the harness is fitted as per the manufacturer's instructions. Never use a harness that is not adjusted correctly as it does not give adequate support in the event of a fall.
2. Check the walkway and the ladder access platform surfaces to ensure they do not have built-up dirt/debris or appear wet and slippery.
3. When walking up the walkway ensure that you maintain 3 points of contact by holding on to the guardrails. Open the gate and step onto the platform ensuring that the access bar is closed. The front guard bar is present between the platform and the excavation to warn users of danger from arrest post.
4. Before connecting to the SRL, disconnect the tag line from the hook and pull the cable down quickly to check that the brake works (the unit should lock with less than 600mm of cable travel).
5. Connect the SRL's hook to the Dorsal Dee ring of the harness. If you cannot see that the attachment has been done correctly, have another worker confirm that the hook is in the correct location and closed properly.
6. Open the access bar by lifting it up. When closing the access bar, lower it slowly into its keeper and do not let it drop as it may swing uncontrollably and cause an injury.



7. Step forward towards the ladder and grip the ladder stile with your hand (if the ladder is on your right side, grip the stile with your left hand and vice versa if the ladder is on the left side). Now maintaining 3 points of contact, step onto the ladder (ensure that the first rung stepped onto is either level with the platform or a maximum of 1 rung down).





► Operating & Safety Instructions

8. Close the access bar.

9. When descending the ladder, maintain 3 points of contact until you reach the bottom of the excavation. You can now disconnect from the SRL. Once disconnected, ensure that you do not let go of the rope line and allow the SRL to recoil unrestrained as this will cause damage to the internals of the SRL. Connect a tag line to the hook of the SRL and allow the cable to retract slowly. Tie the tag line to the ladder to minimise any trip hazard in the excavation. When there is more than one person accessing the excavation, the tag line should be taken down each time with them to ensure the SRL is recoiled properly as described above.



10. When you are ready to climb the ladder, untie the tag line from the ladder base and slowly pull down on the tag line until you have the SRL's hook firmly grasped.



11. Repeat the initial SRL test by quickly pulling down on the cable to check that the SRL is locking correctly.



12. Connect the SRL to the Dorsal Dee on your harness and climb the ladder maintaining three points of contact.



13. Before stepping onto the platform from ladder, open the platform access bar and grasp the front upright on the platform with the hand closest to the platform.

14. Now climb to a level on the ladder from where you can comfortably step on to the platform. Generally, it is recommended that you step from a rung that is level with the platform or no more than one rung lower.

15. When you have both feet on the platform, close the access bar and check that it is latched correctly. Now you can disconnect the SRL, reconnect the tagline and let the rope retract slowly (never allow the rope on an SRL to retract uncontrolled as you may damage the SRL). Pass the loose end of the tag line down the excavation to other workers in order to retrieve the SRL hook. Repeat the process as required.

16. Open the gate on the Shoring Box Platform and slowly walk forwards and down the platform walkway, while maintaining 3 points of contact.



► TWF - Shoring Box Platform

8. INSPECTION

The system must be inspected by a competent person before each use and periodically on a scheduled basis.

Any problems must be reported immediately to the site supervisor and the equipment tagged "Out of Service" to prevent further use until it has been repaired.

8.1 Daily Inspection Procedure

- Inspect the system and all accessories for physical damage, bent parts etc. that may have been caused by an excavator or other plant on the job site. Check also for loose or missing hardware and missing or illegible labels. Replacement labels and accessories for all BTS products are available from your equipment supplier.
- Check that the walkway is in place, the locking bar inserted correctly and the securing clip is on the end of the Locking bar for walkway.
- Check that the 4 clamping screws are tight and that the Shoring Box Platform is sitting correctly (level and the underside of the platform is touching the top of the shoring).
- Check that the gate is operating correctly and that the spring loaded hinges close the gate upon release.
- Ensure that the locking bar is intact and that the pivot bolt is tight.
- Check that the SRL is in place, secured properly (via a karabiner).
- Check the SRL's operation by pulling out a short length of cable and sharply pulling down to check the brake locks.
- Check that the fall arrest indicator on the SRL hook is not showing. If showing, this indicates that the SRL has sustained a fall and must be removed from service.
- Wearing a safety harness and connected to the SRL, check that the ladder is in the correct position, the ladder angle is correct, the ladder protrudes from the structure at least 1 metre (except when the ladder is secured to the leading edge of the platform) and that the ladder bracket is in place with the 2 securing bolts tightened.

8.2 Annual Inspection

An annual inspection must be conducted by a competent person. The Inspection plate on the Fall arrest post needs to be marked with the date of inspection and date of next inspection.

9. MAINTENANCE

9.1 Cleaning and Lubrication

The system has been designed with appropriate clearances allowing them to be assembled and adjusted without the need for lubricants. The system must be clean and free of surface contaminants to work correctly.

Depending on the site conditions, the Ladder Access Platform and walkway may need to be periodically cleaned to remove any built up dirt and debris that may have accumulated. Use a solution of warm water and mild detergent to clean the system.

Do not use solvents or other cleaners to clean the unit, as this may result in damage the surface finish.

9.2 Packaging

For transportation or storage, please ensure the system is disassembled and packed into the supplied stillage and the SRL and bunting flags are stored in the carry bag provided.

The walkway and platform components must be packed into the stillage when transporting or storing.

See next page for Packing instructions.

9.3 Packing of Shipping Box (Stillage)

The system is supplied packed into a steel shipping box (Stillage) to facilitate easy storage, transport and stacking of multiple units. The system need to be repacked after use and before transport to another site.

Please follow the packing directions below.

Note: Item described in each step is highlighted in the diagram in **BLUE**



► Operating & Safety Instructions

1

Position the steel stillage as shown on the right.

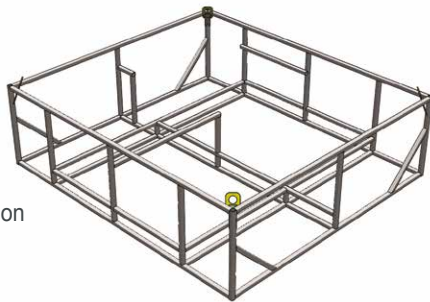

2

Place Guardrail 1 in the stillage.

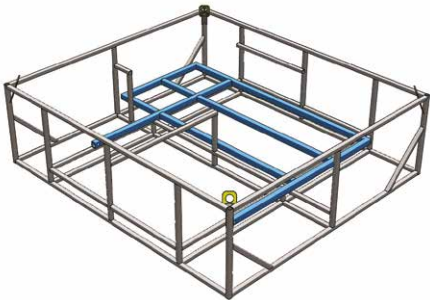

3

Place Guardrail 2 in the stillage.

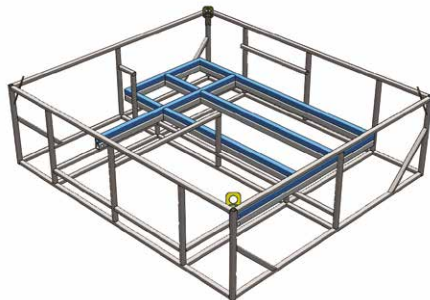

4

Place Platform as shown (feet facing up)

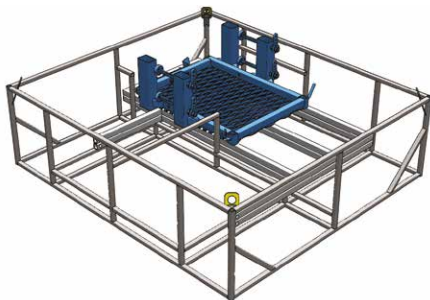

5

Place the walkway as shown. Secure all current parts to the stillage with packing straps.

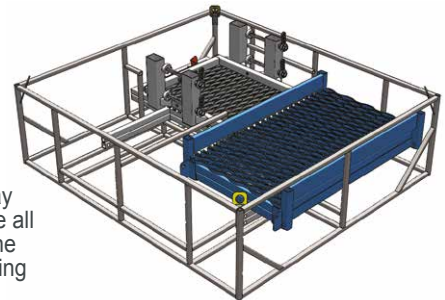

6

Place the Platform Guardrail with spring loaded gate on top of the walkway. Ensure the spring in the hinges is set to minimum.



7

Place the second Platform Guardrail on top. Secure Guardrails to the stillage with packing straps.

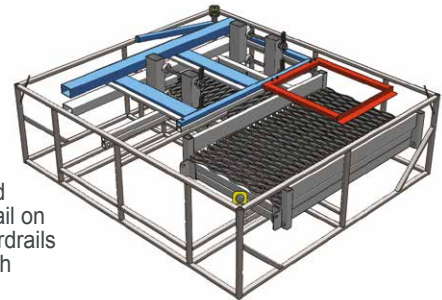

8

Place the Anchor Post as shown. Secure Anchor Post to the stillage with packing straps.

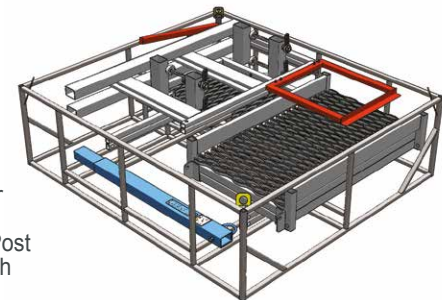

The Walkway, Platform and anchor post are now packed into the stillage and can now be stored or transported. Ensure the SRL and bunting flags are stored in the carry bag provided.



► TWF - Shoring Box Platform

10. INSPECTION LOG

Inspection and recertification of fall arrest systems and equipment is required at least every 12 months by a competent person in accordance with manufacturer's specifications and requirements of EN365:2004.

11. DEFINITIONS

- **SRL:** Self Retracting Lanyard.
- **MAF:** Maximum Arresting Force.
- **EN365:2004:** Personal protective equipment against falls from a height - General requirements for instructions for use, maintenance, periodic examination, repair, marking and packaging.
- **EN360:2002:** Personal protective equipment against falls from a height - Retractable type fall arresters
- **EN361:2002:** Personal protective equipment against falls from a height - Full body harness
- **EN363:2008:** Personal fall protection equipment. Personal fall protection systems
- **Anchor point:** A secure point of attachment to a structure to which a fall-arrest device or an anchorage line may be attached.
- **Competent person:** A person who has, through a combination of training, qualification and experience, acquired knowledge and skills enabling that person to correctly perform a specified task.
- **Full body harness:** An assembly of interconnected shoulder and leg straps, with or without a body belt, designed for attachment to a lanyard, pole strap or fall-arrest device for fall-arrest or work positioning purposes.
- **Karabiner:** A connector having a spring loaded gate with a secondary locking mechanism designed to connect to other connectors or attachment points.
- **RTO:** Registered Training Organisation.
- **kN:** Kilo Newton
- **PPE:** Personal Protective Equipment.
- **Engineer:** A person who is eligible for Corporate Membership of the Institute of Engineers Australia (or local equivalent) and has appropriate experience and competence to assess the integrity of a building, structure and plant.



▶ Operating & Safety Instructions

12. MARKINGS AND LABELS

12.1 Label Location

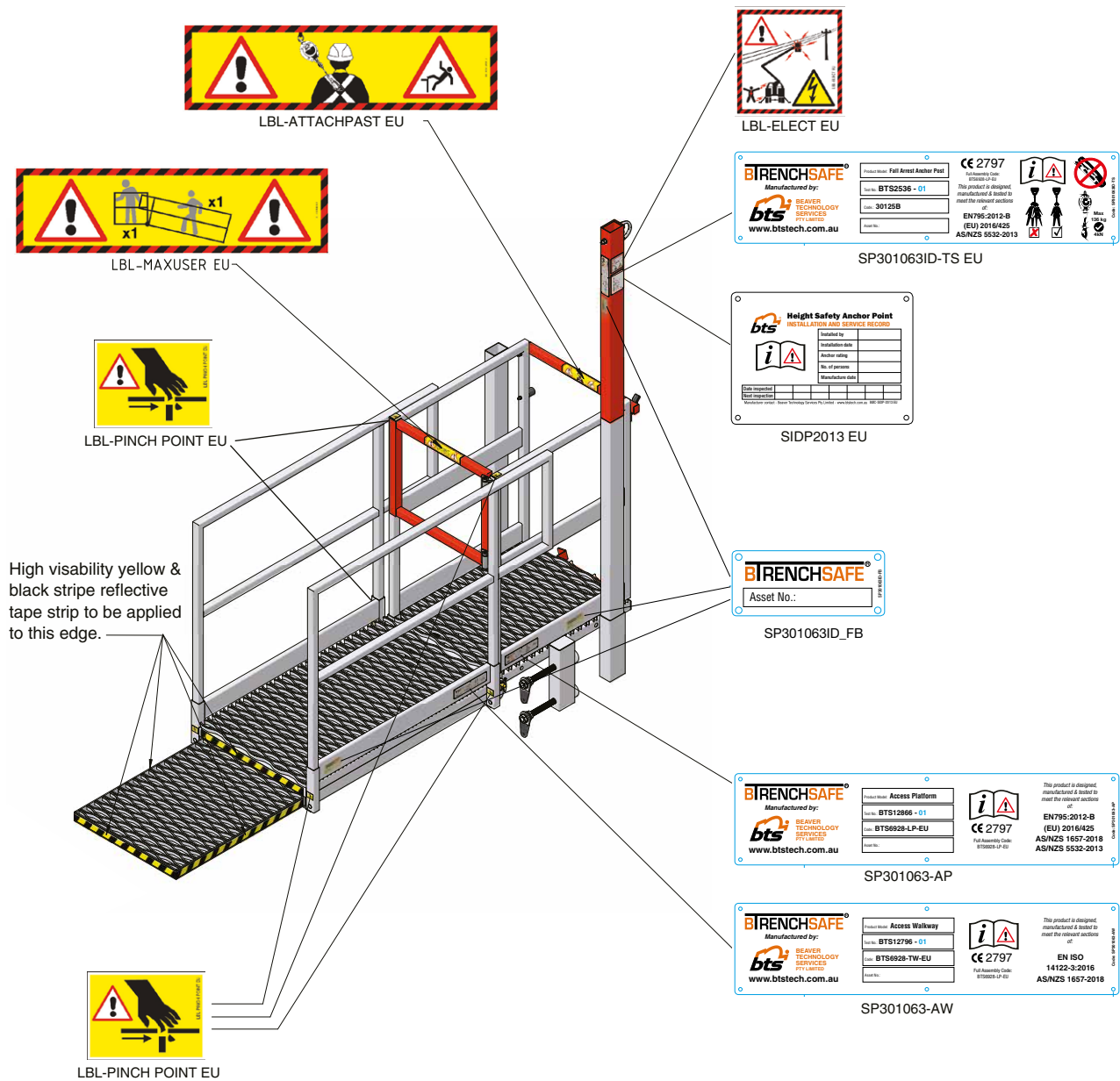

► TWF - Shoring Box Platform

12.2 Label Definitions



CODE: **LBL-ATTACHPAST EU**
DANGER ALL PERSONS MUST BE ATTACHED TO A FALL ARREST DEVICE PAST THIS POINT



CODE: **LBL-MAXUSER EU**
MAX. 2 PEOPLE
ONLY ONE (1) PERSON TO BE ON PLATFORM AT ANY TIME
ONLY ONE (1) PERSON TO BE ON WALKWAY AT ANY TIME



CODE: **LBL-PINCHPOINT EU**
DANGER
PINCH POINT



CODE: **LBL-ELECT EU**
DANGER
ELECTROCUTION HAZARD
WATCH FOR OVERHEAD POWER LINES

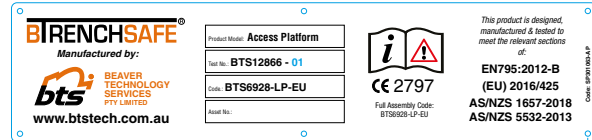

CODE: **SP301063-AP**
B-Trenchsafe Stainless Steel ID Plate for Access Platform (BTS6928-LP EU)

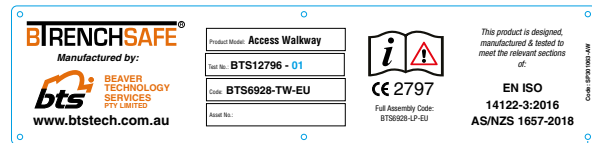

CODE: **SP301063-AW**
B-Trenchsafe Stainless Steel ID Plate for Access Walkway (BTS6928-TW EU)

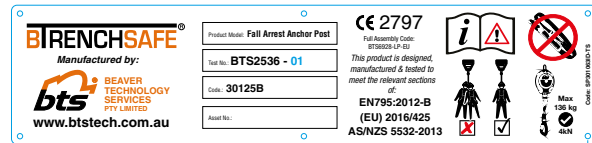

CODE: **SP301063ID-TS EU**
B-Trenchsafe Stainless Steel ID Plate for Anchor Post (BTS6928-LP-EP EU)

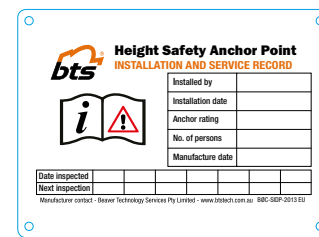

CODE: **SIDP2013 EU**
BTS Stainless Steel Height Safety Anchor Point, Installation and Service Record plate.



CODE: **SP301063ID_FB**
BTS Stainless Steel Asset Number Record plate



► Operating & Safety Instructions

13. COPY OF EC DECLARATION OF CONFORMITY

EC DECLARATION OF CONFORMITY

Beaver Technology Services Pty Ltd
142-146 Magowar Road
Girraween NSW 2145
Australia

Declares that the new PPE,

BTENCHSAFE® Access/Egress Shoring Platform and Telescopic Walkway with Fall Arrest Post Kit

is in conformity with the provisions of PPE Regulation (EU) 2016/425 and, where such is the case, with the national standard transposing harmonized standards

EN795:2012 Type B Anchor device
EN14122-2:2016
EN14122-3:2016

And is identical to the PPE which is the subject of **EC certificate of conformity No CE 706764** issued by **BSI 2797**

BSI Group
Say Building
John M. Keynesplein 9
1066 EP Amsterdam
Netherlands

and is subject to the procedure set out in Module D (Annex VIII) New PPE Regulation (EU) 2016/425 under the supervision of the approved body
British Standards Institution

Done at **Beaver Technology Services, 142-146 Magowar Road, Girraween 2145**

On **7th November 2019**

NOTE:

1. A record of this product must be maintained by the user organization or individual as per section 4.6 of EN365:2004.
2. If system is re-sold in another country, this Operation and Safety instruction manual must be translated to an official language of the destination country.



► TWF - Shoring Box Platform

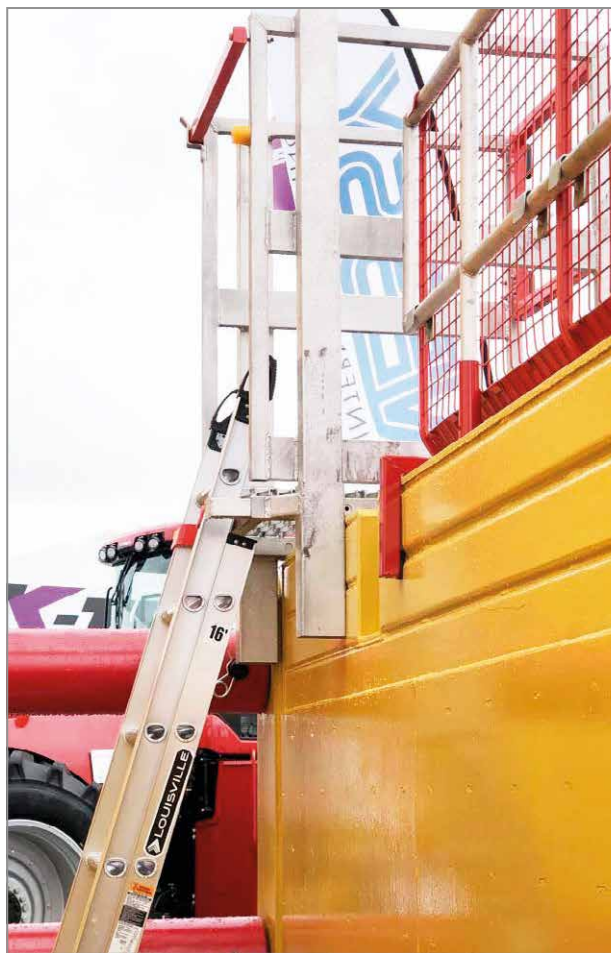



► Operating & Safety Instructions

Inspection Log

System Model No. : Date of Manufacture (dd/mm/yy) :/...../.....

System Serial No. : Purchase Date: (dd/mm/yy) :/...../.....

INSPECTION ITEM	PASS	FAIL	DETAILS / LOCATION OF DAMAGE	DISPOSITION (REPAIRED / SCRAPPED)	APPROVED FOR USE BY:
Check all welds for cracks or damage					
Check anchor point is not damaged and securing bolt is tight					
Check gate closes correctly and that the spring loaded hinges are working					
Check access bar is secured correctly, and opens smoothly					
Check SRL operates correctly, labels are legible and that it is within service date					
Check walkway extension slides in and out smoothly. Ensure stopper is in place preventing extension from becoming dislodged					
Check walkway and platform surface is clean and undamaged					
Check ladder bracket is in place and that securing bolts are in good condition					
Check ladder is in good condition, there is no damage and that the locking mechanism is working					
Check legibility of all warning labels and markings.					

Notes:

Date of Inspection: (dd/mm/yy) / / Next Date of Inspection: (dd/mm/yy) / /

Inspected by:

NOTE:

- 1) A record of this product needs to be maintained by the user organization or individual as per section 4.6 of EN365:2004
- 2) If the system is re-sold in another country, this Operating and Safety Instruction manual needs to be translated to an official language of the destination country.



09-2023



TWF TIEFBAUTECHNIK

Sales | Rental | Leasing



SHORING BOX PLATFORM WALKWAY AND FALL ARREST SYSTEM

TWF Tiefbautechnik GmbH

Düsseldorfer Straße 2, D-52525 Heinsberg, Germany

T: +49 2452 15678-0

F: +49 2452 15678-19

office@twf-tiefbautechnik.de

www.twf-tiefbautechnik.de

TWF International GmbH

Klingerstraße 8, A-1230 Wien

T: +43 1 8653333

F: +43 1 8653333-33

office@twf.at

www.twf.at

OPERATING MANUAL