

# TWF TIEFBAUTECHNIK

Sales | Rental | Leasing



**STANDBOX TYPE 600**

[www.twf-tiefbautechnik.de](http://www.twf-tiefbautechnik.de)

[www.twf.at](http://www.twf.at)

**OPERATING MANUAL**

## ► TWF - Standardbox Shoring Type 600

### Contents

<b>General Instructions</b>	<b>3</b>
Lifting & transporting, Measures to reduce danger, Maintenance & repair	
<b>Technical parameters / System drawings</b>	<b>4 - 5</b>
Base element, Top element, Standard spindle	
<b>Accessories</b>	<b>6</b>
Connector, Pins, Protection rail	
<b>Assembly Instruction / Installation</b>	<b>7 - 11</b>
Assembly Instruction, Place and adjust method, Cut and lower method, Installation of the base boxes, Use of protection rails, Installation of top boxes, Installation of further shoring sections	
<b>Re-Installation</b>	<b>11</b>
Re-Installation instructions	





## ► Operating Manual



### General Instructions

**The shoring must be without gap and close to the ground. The limiting values for the max. loads have to be kept strictly. Single shoring sections (boxes) may only be used if the front and rear faces are properly secured.**

The following rules and regulations have to be followed in their valid version:

- Regulations of the BG-Fachausschuss Tiefbau (technical committee civil and underground engineering)
- DIN 4124 Baugruben und Gräben (excavation pits and trenches)
- DIN EN 13331 Teil 1 & 2 Grabenverbaugeräte (part 1 & 2 construction equipment)
- Regeln für Sicherheit und Gesundheit bei der Arbeit (rules for safety and health during work)
- Unfallverhütungsvorschriften / Arbeitsschutzvorschriften (accident prevention and safety at work rules)

### Lifting and transporting

- The shoring may only be attached at the corresponding eyes and openings and/or lifting accessories.
- The lifting accessories must be adapted to the weight which must be transported.
- For safety reasons only load hooks with hook safety must be used.
- The allowed tensile forces have to be kept in any case.
- The transporting has to be carried out next to the soil and unneeded pendulum movements have to be avoided.
- It is forbidden to enter the swivel range of the lifting tool and to stay under floating loads.

- It has to be paid attention to overhead contact lines.
- Engine driver and instructor must have face-to-face interaction.

### Measures to reduce danger

- The construction site has to be sufficiently secured and marked.
- Neighbouring traffic flow has to be made possible by means of security personnel if needed.
- The personnel must wear protective clothing (helmet / safety shoes / gloves).
- Possible instabilities as a result of wind loads, during the assembly and installation, must be considered.
- The shoring components must be layed down – preferably in horizontal way – on a firm underground.
- In case of slopes it has to focus on a stable storage or mounting of pre-assembled components.

### Maintenance and repair

- As a matter of principle, the operability of all shoring components must be checked before use.
- Defective or deformed components may not be used in any case.
- Slighter damages may be repaired by yourselves after consulting TWF. Otherwise, our service at TWF is at your disposal if desired.
- Only original spare parts of TWF may be used.

According to intenseness of use, the components should be painted with anti-corrosive paint every 2 years



## ► TWF - Standardbox Shoring Type 600

### ■ Standard Box Type 600

- **Solid and hard wearing** - it ensures maximum safety at trench depths up to 5,20 m
- Installation by **lower and cut method** in unstable soils
- Mobile- or crawler excavator: **12 - 18 t** | with top element **18 - 30 t**
- Maximum trench depth: **5,20 m**
- Trench width: **1,20 - 4,49 m**
- Pipe clearance height: **1,50 m**



1	Base element
2	Top element

PH	Panel height
TW	Trench width
WW	Working width
PT	Panel thickness
PCH	Pipe clearance height
PL	Panel length
PCL	Pipe clearance length

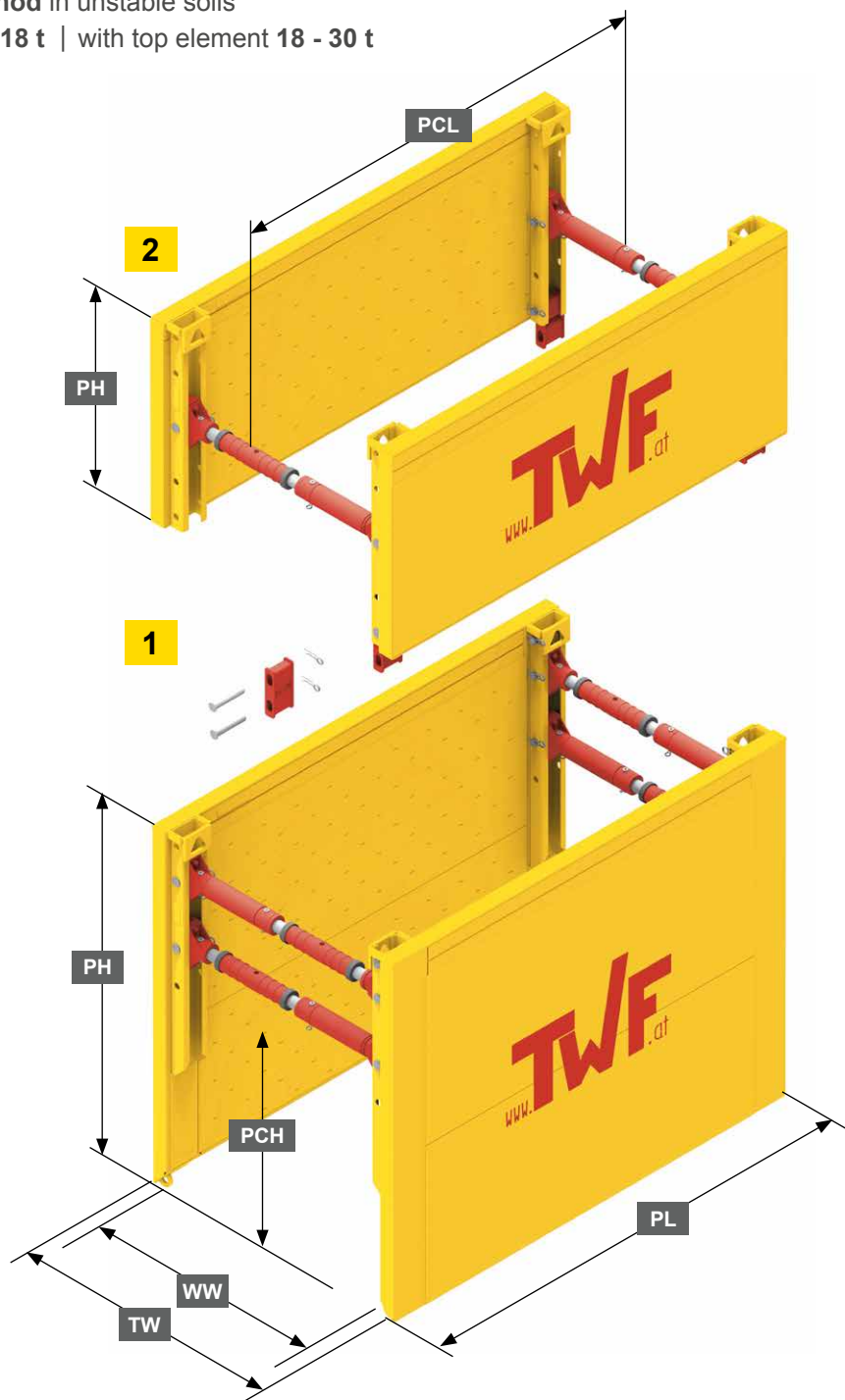



## ► Operating Manual

Element	Panel length PL (m)	Panel height PH (m)	Panel thickness PT (mm)	PC-length PCL (m)	PC-height PCH (m)	Char. system resistance $R_k$ (kN/m <sup>2</sup> )	Weight c/w spindle (kg/box)
1	3,00	2,40 / 2,60	107	2,60	1,30 / 1,50	65,7 / 76,3 *	2007 / 2151
2		1,40					1121
1	3,50	2,40 / 2,60	107	3,10	1,30 / 1,50	56,3 / 65,4 *	2289 / 2463
2		1,40					1289
1	4,00	2,40 / 2,60	107	3,60	1,30 / 1,50	49,3 / 57,2 *	2549 / 2733
2		1,40					1509

\* The char. system resistance is based on the indicated PC-height.

► Other lengths on request!

## ■ Standard Spindle

Number intermediate pipe	Working width WW (m)	Trench width TW (m)	Safe working load (kN)	Weight complete (kg)
0	0,98 – 1,27	1,20 – 1,49	468	65
1	1,48 – 1,77	1,70 – 1,99	403	86
2	1,98 – 2,27	2,20 – 2,49	348	107
3	2,48 – 2,77	2,70 – 2,99	299	128
4	2,98 – 3,27	3,20 – 3,49	254	149
5	3,48 – 3,77	3,70 – 3,99	210	170
6	3,98 – 4,27	4,20 – 4,49	165	191



## ► Transformation profile - special solution



09-2023



## ► TWF - Standardbox Shoring Type 600

### ■ Accessories

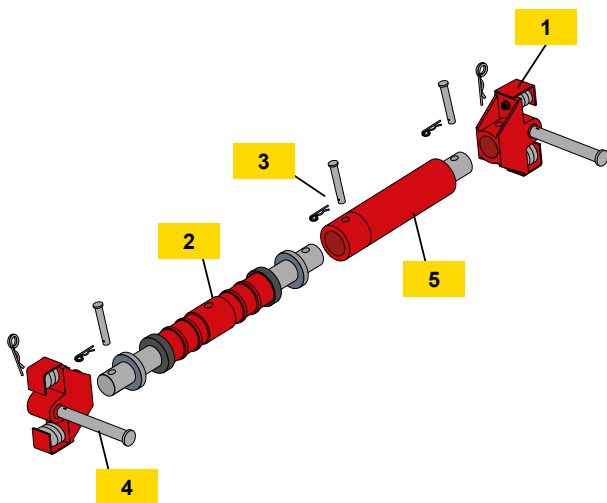

Description	Use for	Dimension (mm)	Weight (kg/ piece)
1 Spring spindle holder	Spindle	95/290 x 193	13,1
2 Spindle	Plates		40,2
3 Pin with clip 4, 5	Extension pipe	Ø20 x 147	0,4
4 Pin with clip 6, 3	Spring spindle holder & connector	Ø40 x 230	2,4
5 Extension pipe	Spindle	Ø121 x 500 Ø121 x L	19,8

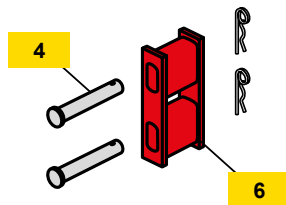

6 Connector	Top plate	Ø70/150 x 325	7,6
-------------	-----------	---------------	-----

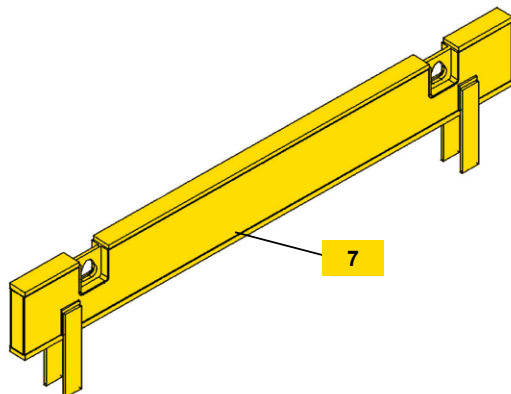

7 Protection rail	Plates PT = 107mm	PL = 3,00 m PL = 3,50 m PL = 4,00 m	410,0 430,0 510,0
-------------------	----------------------	---	-------------------------

## ► Operating Manual

### ■ Assembly instructions

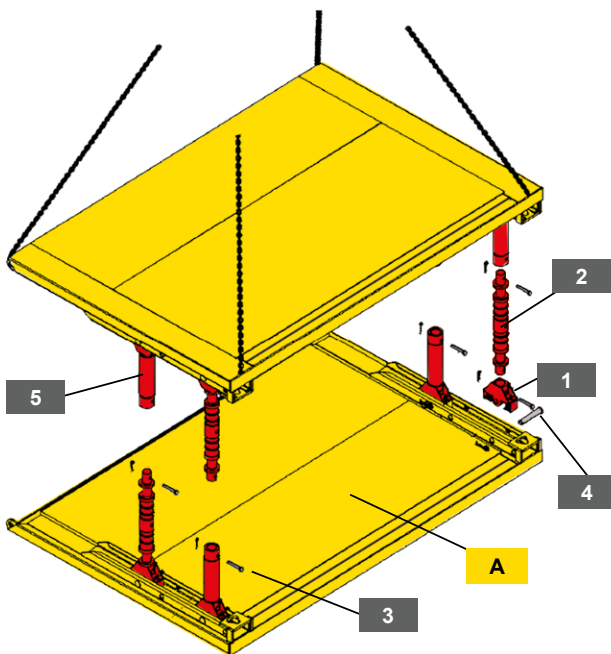

<b>A</b>	Base plate
<b>1</b>	Spring spindle holder
<b>2</b>	Casting spindle
<b>3</b>	Pin Ø20 * 147
<b>4</b>	Pin Ø40 * 230
<b>5</b>	Extension pipe

- Now the spindles are extended/spindled out to the required trench width (fine adjustment).
- Thereby it has to be paid attention that the bottom strut is extended by about 3 – 5 cm more than the upper one, in order to achieve the A-position of the shoring plates.
- The assembly of the top boxes is effected analogously.

- Put the base plates onto a flat and firm underground with the profile to the top.
- Afterwards put the spring spindle holders into the profiles, fix with the pins Ø40x230 mm and secure by means of the clips.
- Put the spindles and extension pipes, respectively staggered, into the spring spindle holders (trench widths up to 2,0 m at one plate – greater widths at two plates) and fix with the pin Ø20x147 mm. Secure the pin by means of the clip.
- The extending up to the required trench width is effected by means of extension pipes as described above.
- After mounting all spindles, one plate is connected to the corresponding lifting/transporting eyes at the top and cutting edge and then put from the top onto the spindle of the plate beneath, pinned and secured.

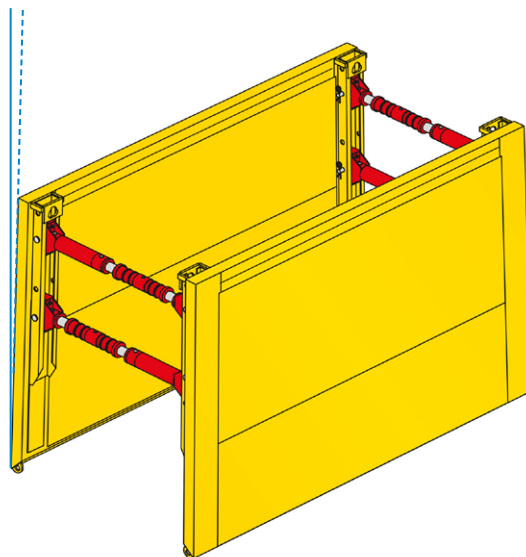

- The shoring width must be shorter above and more wide below. (+ 3 – 5 cm)

## ► TWF - Standardbox Shoring Type 600

### ■ Installation instructions

#### Allowed tensile forces (Shoring plate)

At the single attachment points the following tensile forces can be beared:

per lifting eye at the top = 153 kN

per eye at cutting edge = 49 kN

#### Place and adjust method

The shoring box is placed into the totally pre-excavated trench.

The place and adjust method is allowed only if the following requirements are given:

- Temporary steady soil
- Outside of the sphere of buildings or structural plants
- Outside of the sphere of circulation spaces and endangered lines
- Settlements can be accepted

A soil is characterised as temporary steady if it does not have considerable collapses in the time between start of excavation and placing of the shoring.

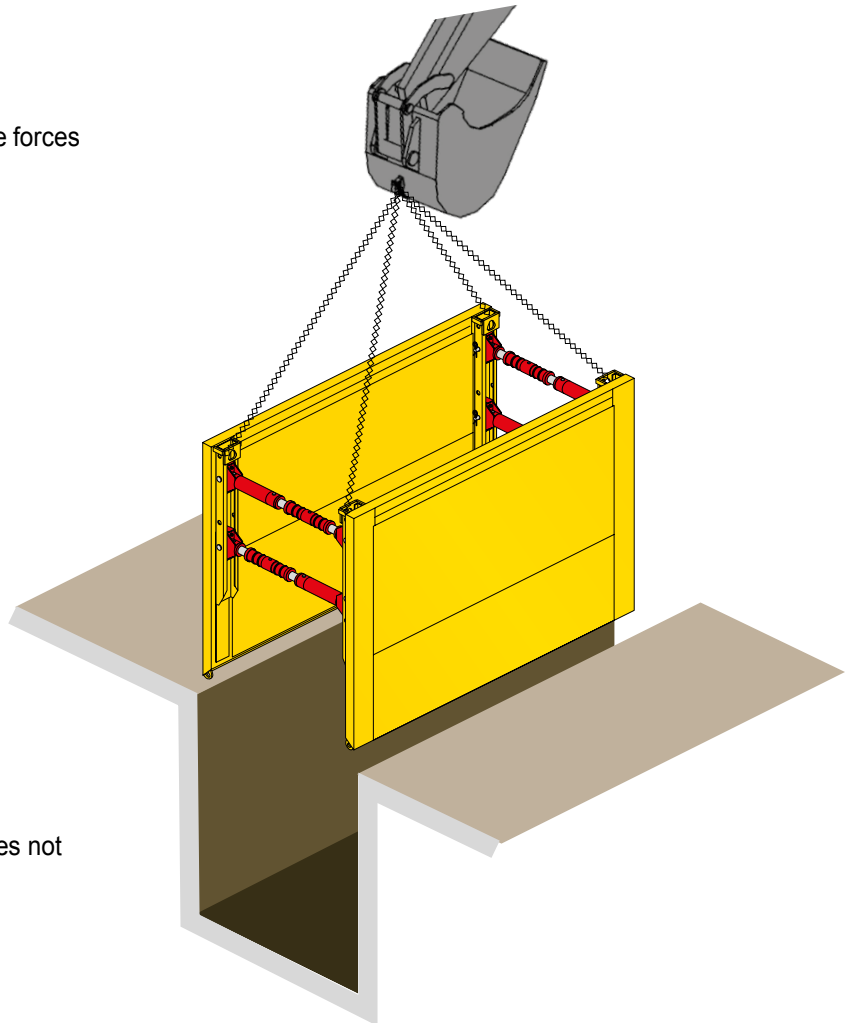

- For trench depths greater than the base plate height, when applying the place and adjust method, base and top boxes must be assembled outside of the trench and placed into the trench as a whole.
- Base and top boxes are connected by means of box connectors and pins and secured with clips.
- Attach the chains to the provided eyes in the profile at least at four points.
- Place the completely assembled base and top box as a whole into the entirely preexcavated trench by means of lifting tools and appropriate lifting accessories.
- The excavation length has to be limited to the box length.
- The opening between shoring and soil has to be filled and compacted.!



## ► Operating Manual

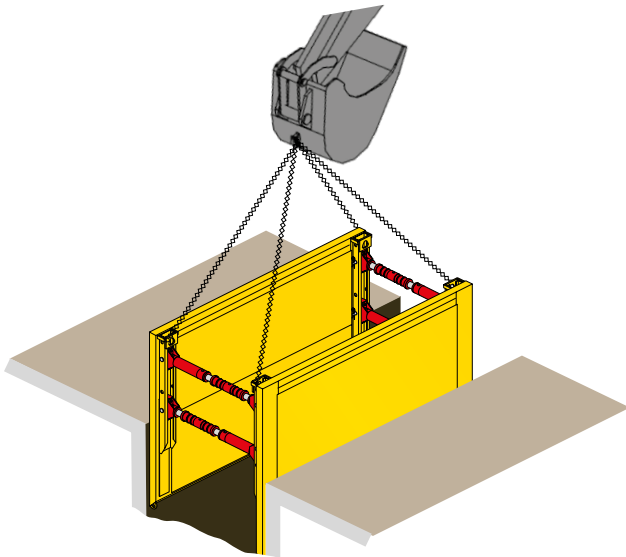

- The shoring plates are to be pushed in and not battered. For safety reasons it is not allowed to push the extension pipes.
- In this phase the trench may not be entered.
- Excavate about further 0,50 m and alternately push in the plates.

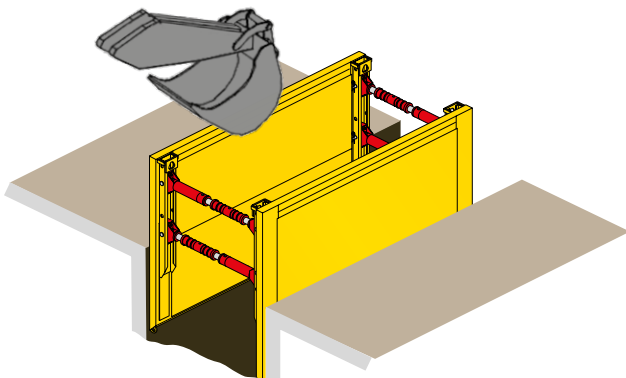

### Installation of the base boxes

- Pre-excavation max. 1,25 m and not more than one shoring section length. In principle the pre-xcavation complies with the type of soil and safety regulations.
- Attach the chains to the four eyes at the profile and place the base box which is spindled out to the required trench width, in the pre-excavated trench, align and push in.
- Fill the opening between shoring and soil and compact!

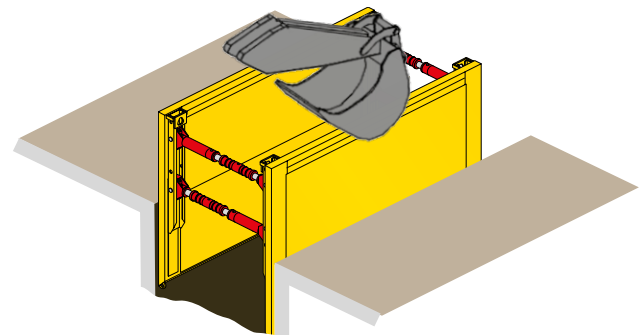

- The smaller the steps or pushes are carried out the better for the shoring! Do not push more than 50 cm the one side and limit the swivelling angle of the spindles to  $\pm 8^\circ$ .
- Repeat this procedure until reaching the required trench depth.

## ► TWF - Standardbox Shoring Type 600

### Use of protection rails

- To protect the shoring plates and ensure a long life cycle we recommend the use of protection rails.

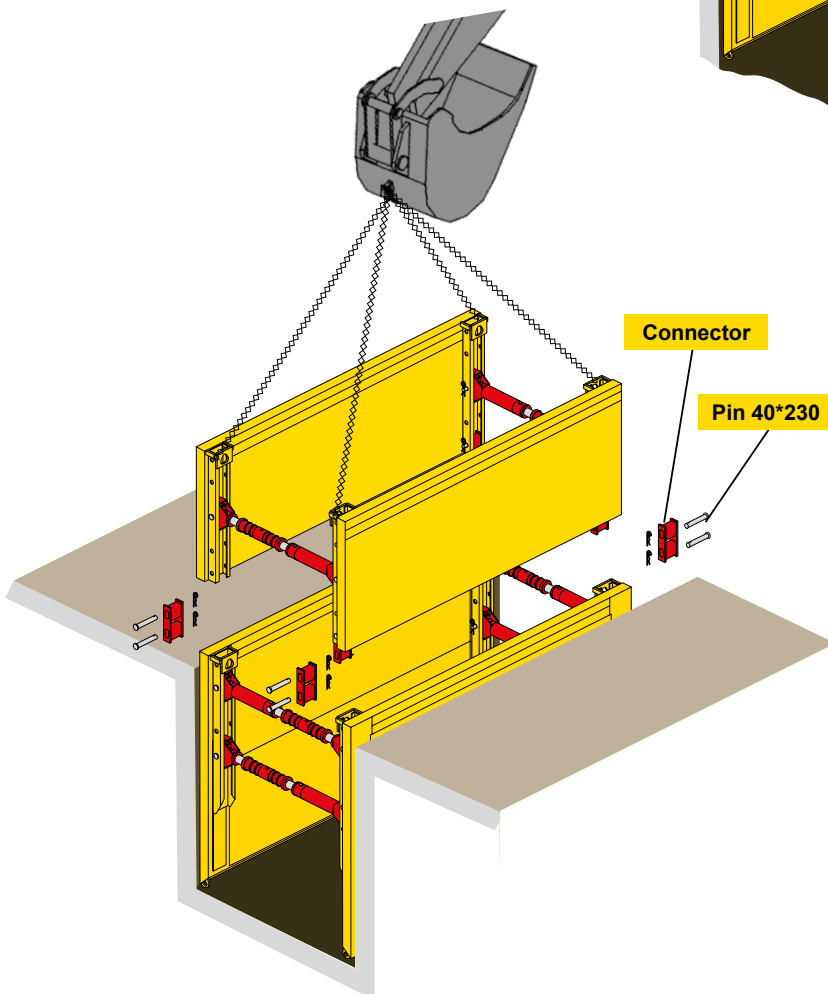
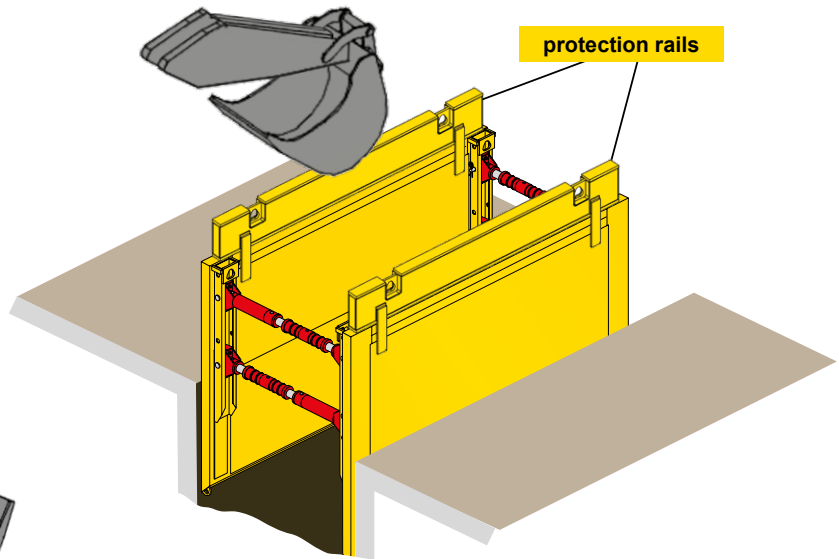

### Installation of top boxes

- For greater trench depths top boxes are to be used. The top box, pre-assembled to trench width, is attached to the four eyes at the profile, aligned over the base box described and connected by means of box connectors and pins  $\text{Ø}40 \times 230$  mm.
- The further installation is effected as above by alternately excavating and pushing in of the shoring plates.
- The top edge of the shoring must overlap the surrounding site by at least 5 cm!

## ► Operating Manual

### Installation of further shoring sections

- Once the foregoing shoring section is installed to full depth, it can be started with the next shoring section.
- The installation is effected analogously as described before.
- After the installation of the shoring boxes, the pipe laying can be started in the shored and secured trench.

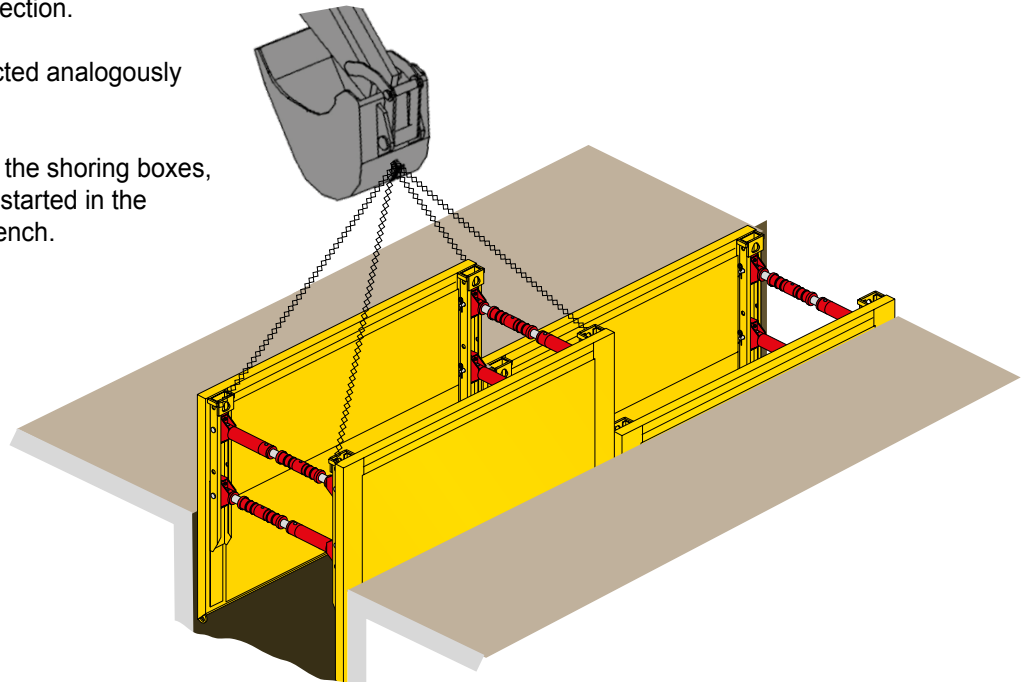

### Re-Installation

- After completion of the pipe laying the reinstallation of the shoring is effected.
- According to compacting possibilities bring in about 0,50m filling material. Lift the shoring box by the filled height. That followed the compaction of the filling material.
- The smaller the lifting steps the better for the shoring! Do not lift more than 0,50 cm to one side and limit the swivelling angle of the spindles to  $\pm 8^\circ$ .
- Repeat this procedure as described until the shoring can be lifted out of the trench according to the safety regulations.
- Only use the corresponding eyes for the lifting. It is not allowed to lift at the extension pipes!
- We advise specifically that it is forbidden to enter the danger zone during the installation and re-installation.
- In order to avoid an overstraining of the shoring plates, do not lift onesided. Attach lifting accessories at least at 2 eyes of the particular plate.

# TWF TIEFBAUTECHNIK

Sales | Rental | Leasing



## STANDBOX TYPE 600

### **TWF Tiefbautechnik GmbH**

Düsseldorfer Straße 2, D-52525 Heinsberg, Germany

T: +49 2452 15678-0

F: +49 2452 15678-19

office@twf-tiefbautechnik.de

www.twf-tiefbautechnik.de

### **TWF International GmbH**

Klingerstraße 8, A-1230 Wien

T: +43 1 8653333

F: +43 1 8653333-33

office@twf.at

www.twf.at

OPERATING MANUAL