

## ► TWF Trench Shoring Systems

### ■ Manhole Box Type 600

- **Solid and hard wearing** - ensures maximum safety at trench depths up to **5,20 m**
- Installation by **lower and cut method** in unstable soils
- Mobile- or crawler excavator: **18 - 30 t**
- Maximum trench depth: **5,20 m**
- Trench width: **2,00 - 5,29 m**
- Pipe clearance height: **1,50 m**

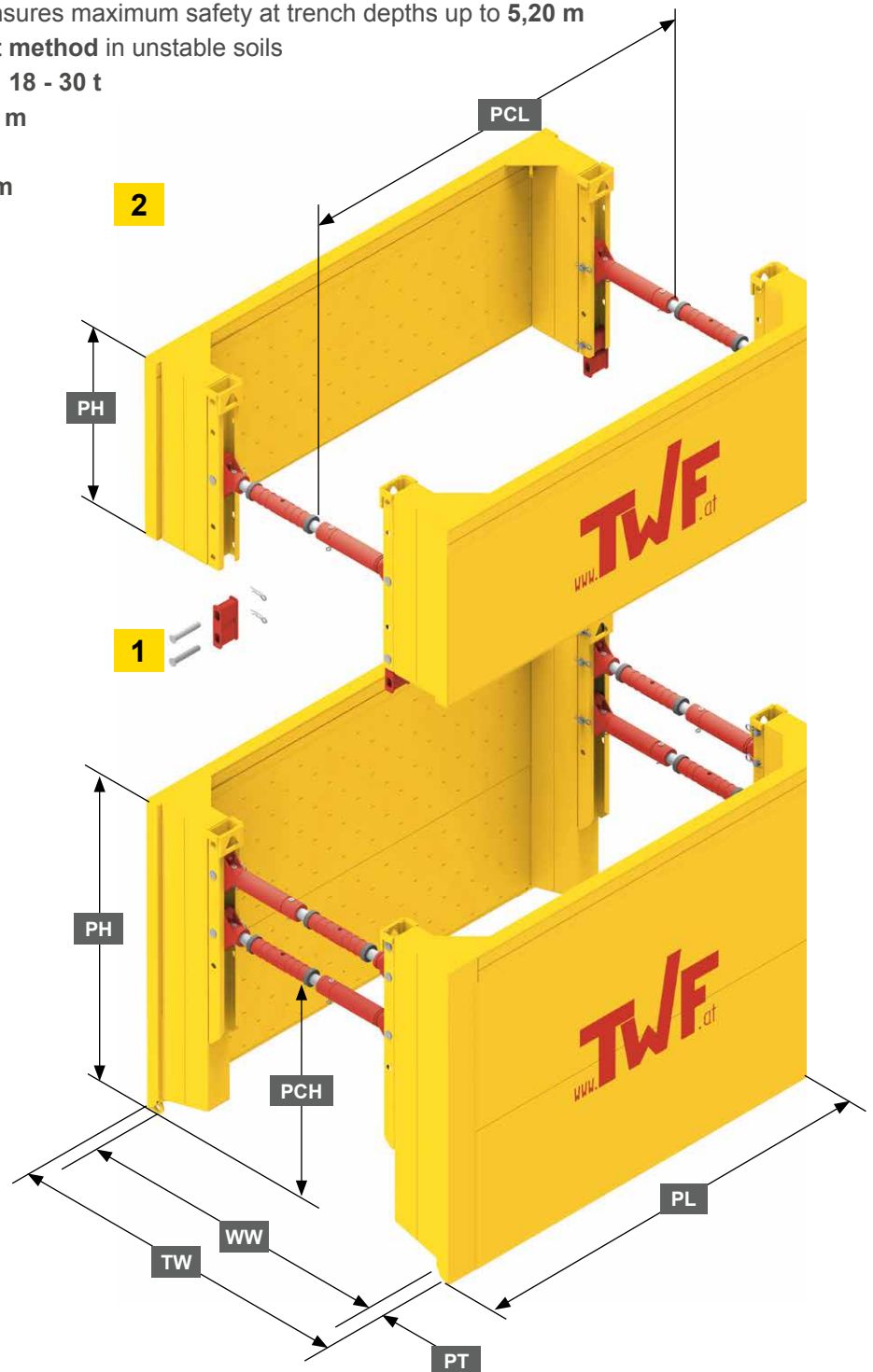

1	Base element
2	Top element

PH	Panel height
TW	Trench width
WW	Working width
PT	Panel thickness
PCH	Pipe clearance height
PL	Panel length
PCL	Pipe clearance length



## ► Manhole Box Type 600

Element	Panel length PL (m)	Panel height PH (m)	Panel thickness PT (mm)	PC-length PCL (m)	PC-height PCH (m)	Char. system resistance $R_x$ (kN/m <sup>2</sup> )	Weight c/w spindle (kg/box)
1	3,00	2,40	107	2,60	1,30 / 1,50	65,7 / 76,3 *	2623
2		1,40					1599
1	3,50	2,40	107	3,40	1,30 / 1,50	56,3 / 65,3 *	2968
2		1,40					1706
1	4,00	2,40	107	3,60	1,30 / 1,50	49,2 / 57,2 *	3221
2		1,40					1853

\* The char. system resistance is based on the indicated PC-height.

► Other lengths on request!

## ■ Standard Spindle

Number intermediate pipe	Working width WW (m)	Trench width TW (m)	Safe working load (kN)	Weight complete (kg)
0	1,78 – 2,07	2,00 – 2,29	468	65
1	2,28 – 2,57	2,50 – 2,79	403	86
2	2,78 – 3,07	3,00 – 3,29	348	107
3	3,28 – 3,57	3,50 – 3,79	299	128
4	3,78 – 4,07	4,00 – 4,29	254	149
5	4,28 – 4,57	4,50 – 4,79	210	170
6	4,78 – 5,07	5,00 – 5,29	165	191

