

TWF TIEFBAUTECHNIK

Sales | Rental | Leasing



**LIGHT WEIGHT SHORING
TYPE 100**

www.twf-tiefbautechnik.de

www.twf.at

OPERATING MANUAL

► TWF - Light Weight Shoring Type 100

Contents

	3
■ Technical description - System drawings	4-5
Plates	4-5
Light Weight Spindle	5
Telescopic Strut	5
Accessories	4-5
■ General instructions	6
Lifting & transporting	6
Measures to reduce danger	6
Maintenance & repair	6
■ Assembly instructions	7
■ Installation instructions	8-9
Allowed tensile forces	8
Place and adust method	8
Installation of further shoring sections	9
■ Re-Installation	9



► Operating Manual



► TWF - Light Weight Shoring Type 100

■ Light Weight Shoring Type 100

- For **small to medium-sized construction projects** (utility lines, house connections etc.)
- Installation with **place and adjust method** in stable soils
- Mobile excavator: **9 - 13 t**
- Maximum trench depth: **3,00 m**
- Trench width: **0,66 - 2,23 m**
- Pipe clearance height: **0,94 m**

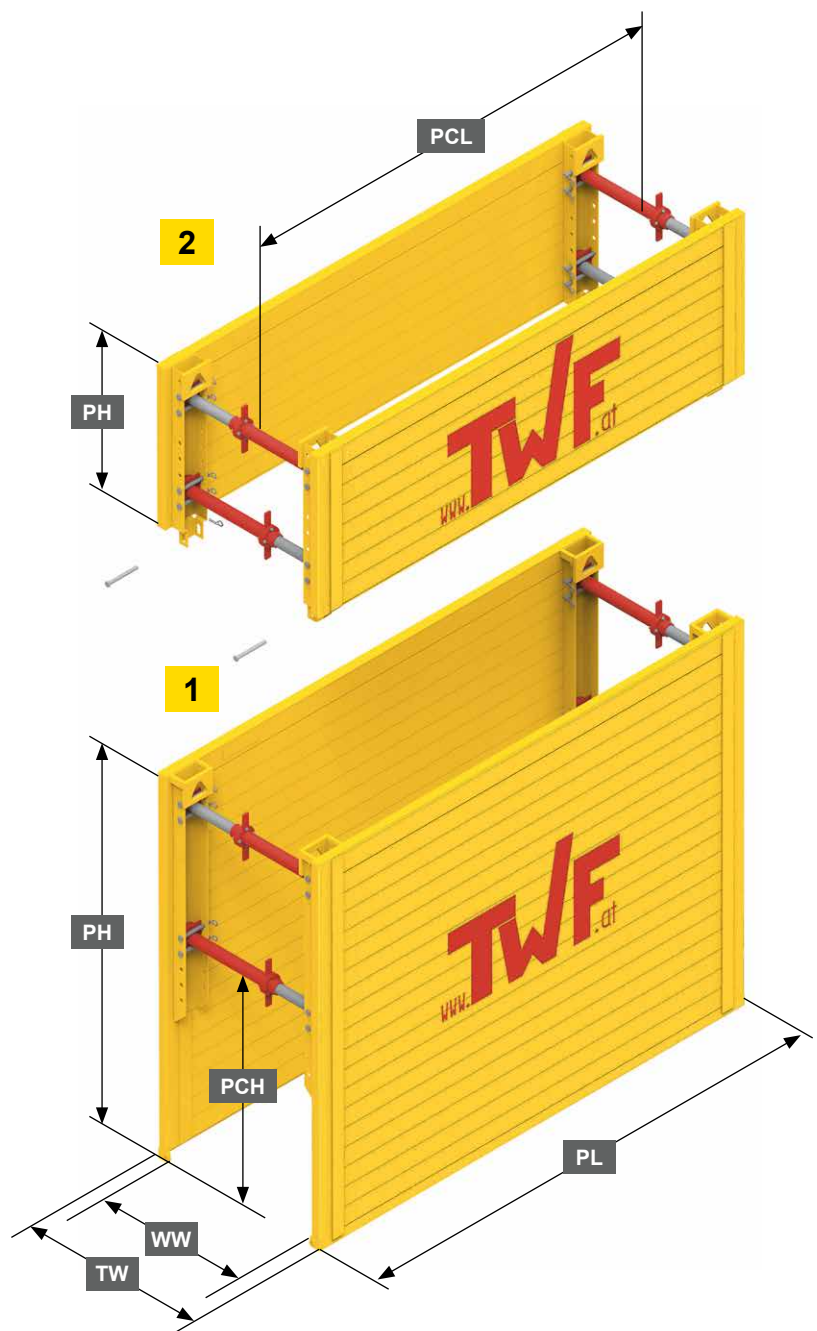

1	Base element
2	Top element
PH	Panel height
TW	Trench width
WW	Working width
PT	Panel thickness
PCH	Pipe clearance height
PL	Panel length
PCL	Pipe clearance length

► Operating Manual

Element	Panel length PL (m)	Panel height PH (m)	Panel thickness PT (mm)	PC-length PCL (m)	PC-height PCH (m)	Char. system resistance R_k (kN/m ²)	Weight c/w strut B (kg/box)
1	2,00	1,60 2,00 2,40 2,60	60	1,60	0,94	47,8	570 674 766 812
2		0,60 1,00					310 470
1	2,50	1,60 2,00 2,40 2,60	60	2,10	0,94	38,3	634 774 914 984
2		0,60 1,00					370 568
1	3,00	1,60 2,00 2,40 2,60	60	2,60	0,94	31,9	736 904 1068 1150
2		0,60 1,00					430 536
1	3,50	1,60 2,00 2,40 2,60	60	3,10	0,94	27,3	830 1040 1200 1280
2		0,60 1,00					490 592

■ Light Weight Spindle

Type	Working width WW (m)		Trench width TW (m)		Safe working load (kN)	Weight complete (kg)
	min.	max.	min.	max.		
A	0,53	0,73	0,66	0,86	160	13,2
B	0,71	1,07	0,84	1,20	147	16,0
C	1,05	1,65	1,18	1,78	124	19,5
D	1,50	2,10	1,63	2,23	107	22,5

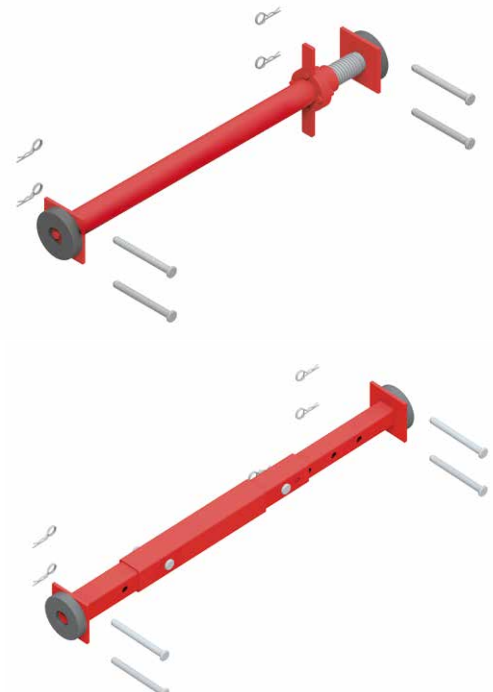

■ Telescopic Strut

Type	Working width WW (m)		Trench width TW (m)		Safe working load (kN)	Weight complete (kg)
	min.	max.	min.	max.		
0	0,57	0,77	0,70	0,90	169	9,5
1	0,82	1,29	0,95	1,42	159	15,0
2	1,34	1,80	1,47	1,93	149	20,5
3	1,85	2,32	1,98	2,45	132	26,0
4	2,37	2,83	2,50	2,96	103	31,5

► **Telescopic Strut**
optional for Type 100
for working widths
from 570 mm to 2830 mm

► TWF - Light Weight Shoring Type 100

■ General Instructions

The shoring must be without gap and close to the ground. The limiting values for the max. loads have to be kept strictly. Single shoring sections (boxes) may only be used if the front and rear faces are properly secured.

The following rules and regulations have to be followed in their valid version:

- Regulations of the BG-Fachausschuss Tiefbau (technical committee civil and underground engineering)
- DIN 4124 Baugruben und Gräben (excavation pits and trenches)
- DIN EN 13331 Teil 1 & 2 Grabenverbaugeräte (part 1 & 2 construction equipment)
- Regeln für Sicherheit und Gesundheit bei der Arbeit (rules for safety and health during work)
- Unfallverhütungsvorschriften / Arbeitsschutzvorschriften (accident prevention and safety at work rules)

Lifting and transporting

- The shoring may only be attached at the corresponding eyes and openings and/or lifting accessories.
- The lifting accessories must be adapted to the weight which must be transported.
- For safety reasons only load hooks with hook safety must be used.
- The allowed tensile forces have to be kept in any case.
- The transporting has to be carried out next to the soil and unneeded pendulum movements have to be avoided.

- It is forbidden to enter the swivel range of the lifting tool and to stay under floating loads.
- It has to be paid attention to overhead contact lines.
- Engine driver and instructor must have face-to-face interaction.

Measures to reduce danger

- The construction site has to be sufficiently secured and marked.
- Neighbouring traffic flow has to be made possible by means of security personnel if needed.
- The personnel must wear protective clothing (helmet / safety shoes / gloves).
- Possible instabilities as a result of wind loads, during the assembly and installation, must be considered.
- The shoring components must be layed down – preferably in horizontal way – on a firm underground.
- In case of slopes it has to focus on a stable storage or mounting of pre-assembled components.

Maintenance and repair

- As a matter of principle, the operability of all shoring components must be checked before use.
- Defective or deformed components may not be used in any case.
- Slighter damages may be repaired by yourselves after consulting TWF. Otherwise, our service at TWF is at your disposal if desired.
- Only original spare parts of TWF may be used.

According to intenseness of use, the components should be painted with anti-corrosive paint every 2 years.

► Operating Manual

■ Assembly Instructions

- Put the base plates onto a flat and firm underground with the profile to the top.
- Afterwards put the struts (with the thread respectively staggered down and accordingly upwards) into the profiles and fix with 2 pins $\text{Ø} 20 \times 212 \text{ mm}$ and secure by means of the clips.
- After mounting all struts, the second plate is connected to the corresponding lifting/transporting eyes at the top and at the cutting edge and then put from the top onto the struts of of

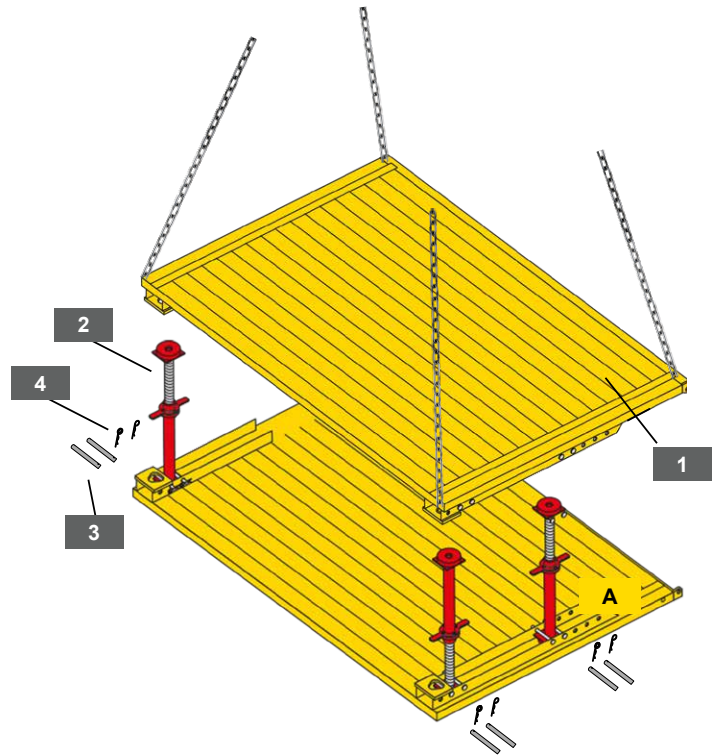

1	Base plate
2	Strut
3	Pin $\text{Ø} 20 \times 212 \text{ mm}$
4	Clip 4,5 mm

- Now the struts are extended to the required trench width. (fine adjustment)
- Thereby it has to be paid attention that the bottom strut is extended by about 3 – 5 cm more than the upper one, in order to achieve the A-position of the shoring plates.
- The shoring width must be shorter above and more wide below.
- The assembly of the top boxes is effected analogously.

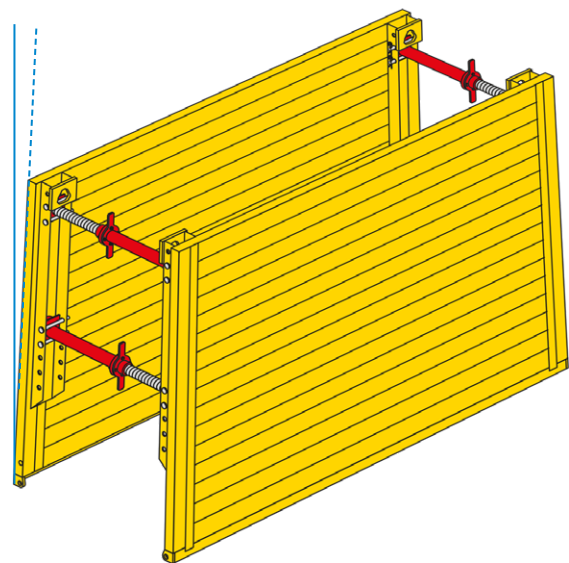

► TWF - Light Weight Shoring Type 100

■ Installation Instructions

Allowed tensile forces (Shoring Plate)

At the single attachment points the following tensile forces can be beared:

per lifting eye at the top = 153 kN
per eye at cutting edge = 49 kN

Place and adjust method

The shoring box is placed into the totally pre-excavated trench.

The place and adjust method is allowed only if the following requirements are given:

- Temporary steady soil
- Outside of the sphere of buildings or structural plants
- Outside of the sphere of circulation spaces and endangered lines
- Settlements can be accepted

A soil is characterised as temporary steady if it does not have considerable collapses in the time between start of excavation and placing of the shoring.

- For trench depths greater than the base plate height, when applying the place and adjust method, base and top boxes must be assembled outside of the trench and placed into the trench as a whole.
- Base and top boxes are connected by means of the pins $\varnothing 20 \times 212$ mm and secured with clips.
- Attach the chains to the provided eyes in the profile at least at four points.
- Place the completely assembled base and top box as a whole into the entirely preexcavated trench by means of lifting tools and appropriate lifting accessories.
- The excavation length has to be limited to the box length.
- The opening between shoring and soil has to be filled and compacted.
- The top edge of the shoring must overlap the surrounding site by at least 5 cm!

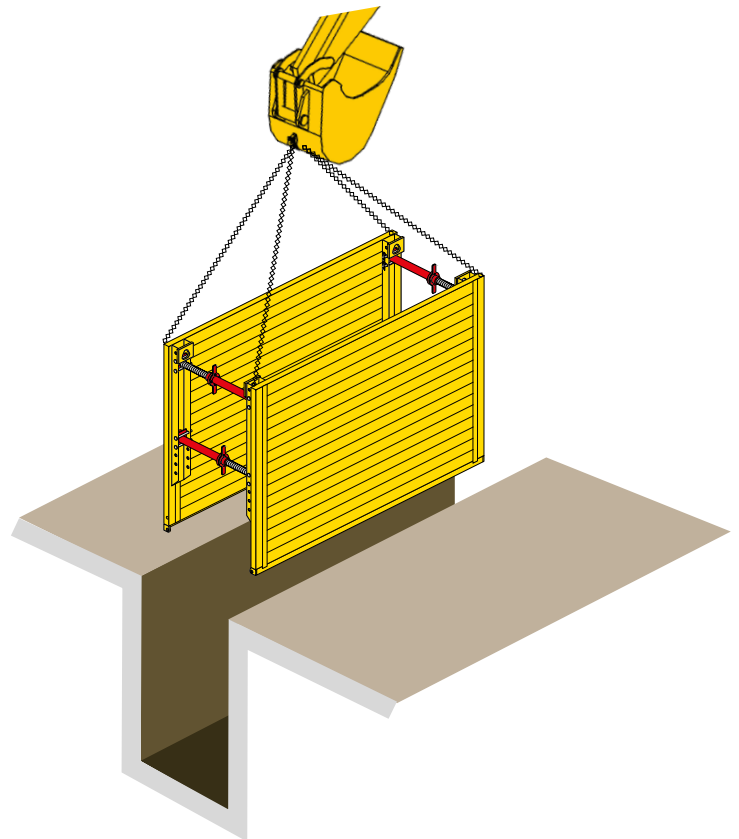

► Operating Manual

Installation for further shoring sections

- Once the foregoing shoring section is installed to full depth, it can be started with the next shoring section.
- The installation is effected analogously as described before.
- After the installation of the shoring boxes, the pipe laying can be started in the shored and secured trench.

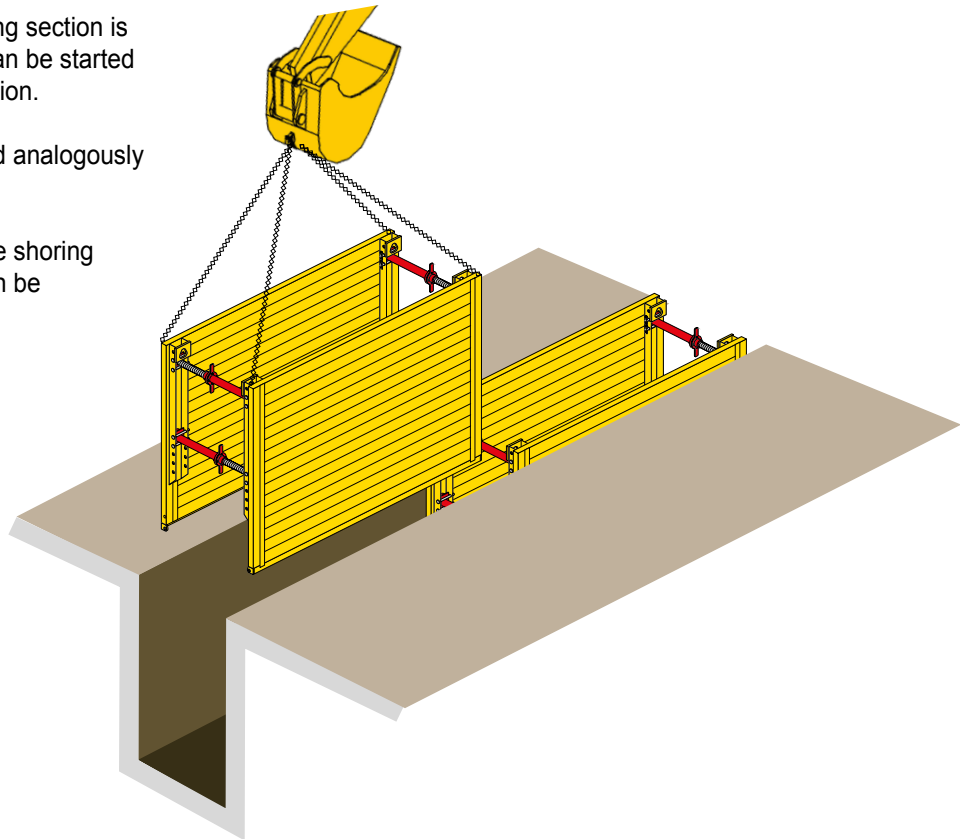

Re-Installation

- After completion of the pipe laying the reinstallation of the shoring is effected.
- According to compacting possibilities bring in about 0,50m filling material. Lift the shoring box by the filled height. That followed the compaction of the filling material.
- The smaller the lifting steps the better for the shoring! Do not lift more than 0,50 cm.
- Repeat this procedure as described until the shoring can be lifted out of the trench according to the safety regulations.
- Only use the corresponding eyes for the lifting. It is not allowed to lift at the struts.
- We advise specifically that it is forbidden to enter the danger zone during the installation and re-installation.
- In order to avoid an overstraining of the shoring plates, do not lift onesided. Attach lifting accessories at least at 2 eyes of the particular plate.

TWF TIEFBAUTECHNIK

Sales | Rental | Leasing



LIGHT WEIGHT SHORING TYPE 100

TWF Tiefbautechnik GmbH

Düsseldorfer Straße 2, D-52525 Heinsberg, Germany

T: +49 2452 15678-0

F: +49 2452 15678-19

office@twf-tiefbautechnik.de

www.twf-tiefbautechnik.de

TWF International GmbH

Klingerstraße 8, A-1230 Wien

T: +43 1 8653333

F: +43 1 8653333-33

office@twf.at

www.twf.at

OPERATING MANUAL